

Building the Future of High-Power Accelerators: Opportunities at LANSCE

Charles Taylor, LANSCE operations physics team leader

Evgenya Simakov, Group Leader, Accelerator Operation and Technology (AOT)- Applied Electrodynamics (AE)

March 13, 2026

LA-UR-26-21432

LANSCCE Purpose



CIC-9: RN91-240-309

- The Los Alamos Neutron Science Center (LANSCCE) accelerator facility provides many opportunities for nation-wide science and technology programs
- Historically delivers 800-MeV proton beams to six facilities simultaneously
- Three major Department of Energy (DOE) Stakeholders:
 - Defense Programs (DP)
 - DOE Office of Science
 - Office of Nuclear Energy, Science and Technology (NE)
- Studies at LANSCCE include:
 - Nuclear weapons program
 - National security research
 - Radioisotope production
 - Basic science- (neutrino & dark matter searches)

LANSCCE Beam Delivery

- LANSCE has 54 years of beam delivery to experimental facilities.
- It was originally named the Los Alamos Muon Production Facility (LAMPF) and has produced a wealth of scientific data (e.g. muon cross-section tables)
- Spallation neutrons are produced for three of the facilities with differing beam structures:
 - High intensity for material strength and electronics aging studies
 - Short pulse structure for refined timing resolution interaction cross-section studies
 - Slow thermal neutron studies for fundamental physics
- Proton pulse trains for ultra-fast, deeply penetrating images of critical events
- Early beam extraction uses 100-MeV protons to produce medical isotopes

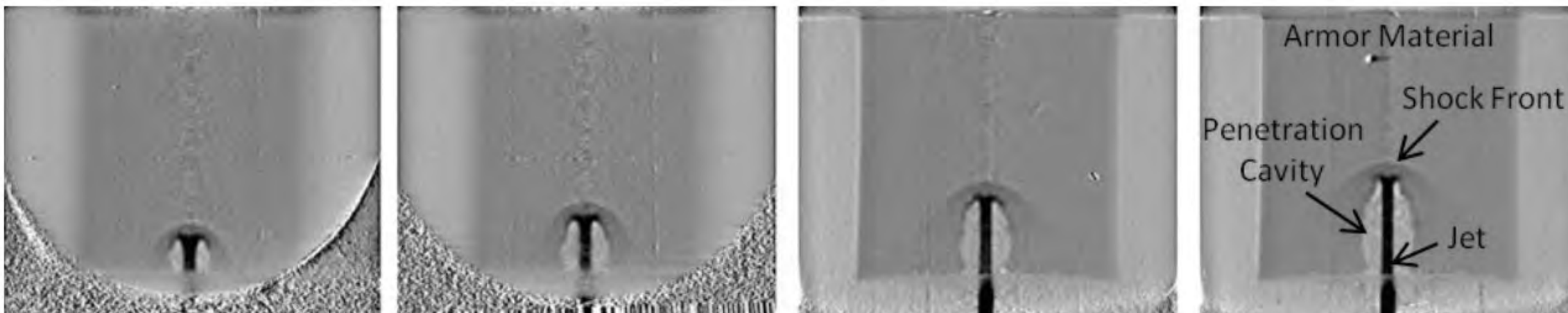

Outline of Today's Presentation

- The Los Alamos National Laboratory (LANL) highlights
- LANSCE's impact to LANL's missions
- How LANSCE works
- How we tune the accelerator (new methods in development)
- Aging & challenges (sustainment projects)
- The LANSCE Modernization Project (LAMP) and LANSCE Enhancement (LANE) project
- Why LANSCE is fascinating

National Laboratories in the United States

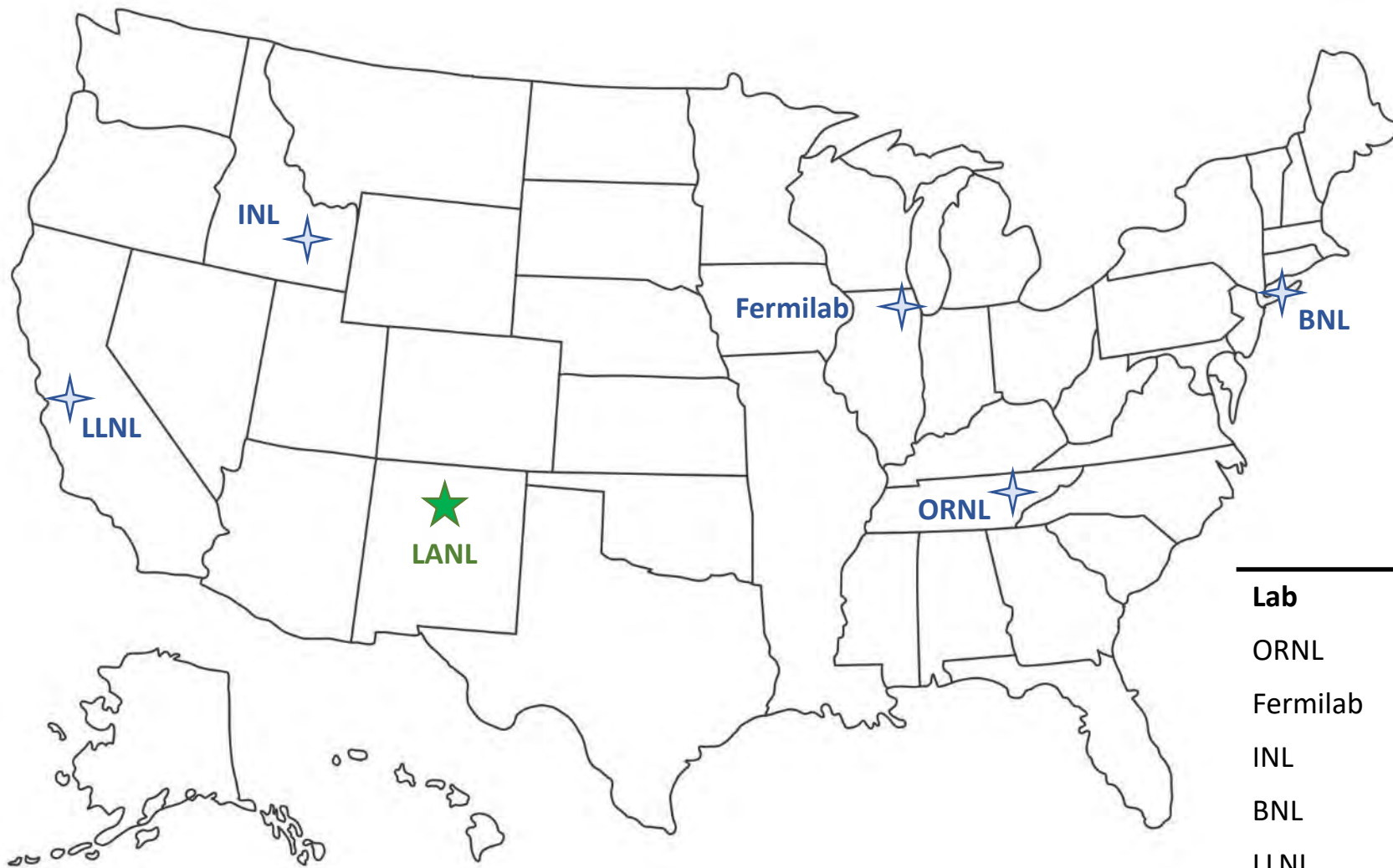

- 17 U.S. Department of Energy (DOE) National Laboratories

- Support:
 - National security
 - Energy innovation
 - Fundamental science
 - Advanced computing
 - Materials & nuclear research

Lab	Known For
ORNL	Neutron science (SNS)
Fermilab	High-energy physics
INL	Nuclear Reactors
BNL	RHIC collider
LLNL	Weapons design + NIF
LANL	Weapons design + high-power accelerators

Los Alamos National Laboratory History

- 1943 – Founded
 - Established as Project Y of the Manhattan Project
 - Led by J. Robert Oppenheimer
 - Designed and built the first atomic bombs
- 1945 – Trinity Test
 - First nuclear detonation (July 16, 1945)
 - Beginning of the nuclear age
- 1952–1980s – Cold War Era
 - Thermonuclear weapon development
 - Advanced nuclear design capabilities
 - Birth of modern weapons physics
- 1972 – LAMPF Commissioned
 - 800-MeV proton accelerator
 - Later renamed LANSCE
 - Foundation for nuclear data & neutron science
- 1990s–2000s – Stockpile Stewardship Era
 - Transition from nuclear testing to:
 - Advanced simulations
 - Subcritical experiments
 - Accelerator-based validation
- 2010s – High-Performance Computing
 - **Trinity** – One of the first petascale-class systems for NNSA.
 - Multiphysics weapons modeling
 - New Climate, atmospheric, wildfire modeling methods
 - Solid-state battery material studies
- 2020s – Modernization & Future
 - **Crossroads** – Advanced computing for multiphysics modeling
 - Astrophysics, neutron scattering, pandemic modeling
 - Plutonium pit production mission
 - LAMP (LANSCE modernization)
 - Scorpius & future accelerator projects



Los Alamos Neutron Science Center

In beam production since 1972



Space & Radiation Effects

- High-energy neutron environment simulation
- Electronics survivability testing
- Radiation hardness validation

Medical & Industrial Isotopes

- Proton beam for isotope production (IPF)
- ^{67}Cu , ^{225}Ac , ^{99}Mo production
- National supply chain support

Stockpile Stewardship

- Proton Radiography (pRad) for dynamic imaging
- Nuclear cross-section measurements (WNR) Radiation effects testing
- Materials characterization under irradiation

Material Science & Manufacturing

- Neutron diffraction & scattering (Lujan Center)
- Residual stress measurements
- Texture analysis
- Additive manufacturing characterization

Nuclear Data and Fundamental Physics

- High-energy pulsed neutron beams
- Time-of-flight cross-section measurements
- Ultra-cold neutron experiments
- Validation data for simulation codes

Future Science & Modernization

- Accelerator R&D (LAMP, LANE)
- Training of next-generation accelerator scientists
- Platform for future experimental areas (Area A)

The LANSCE Complex

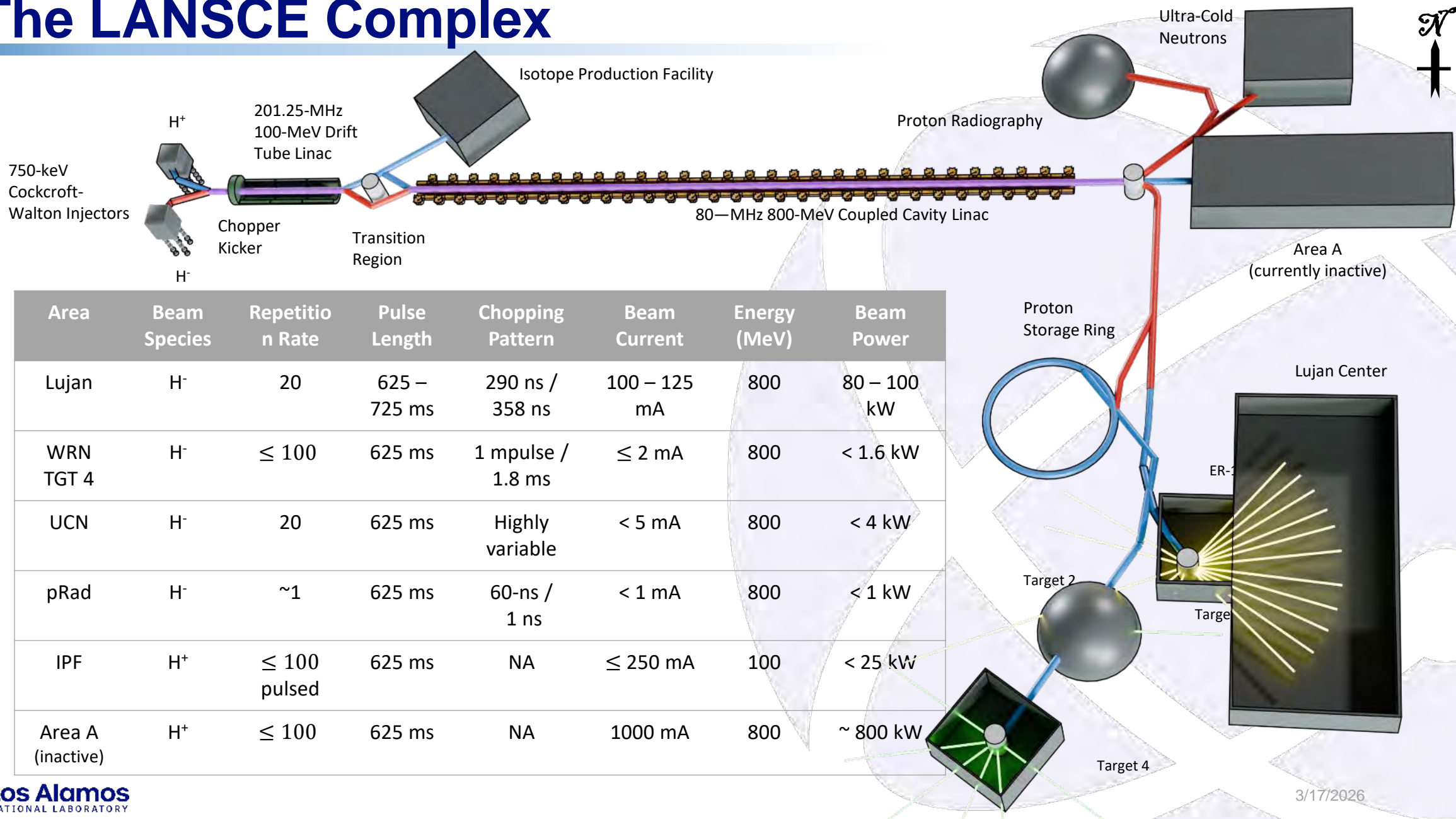

Area	Beam Species	Repetition Rate	Pulse Length	Chopping Pattern	Beam Current	Energy (MeV)	Beam Power
Lujan	H^-	20	625 – 725 ms	290 ns / 358 ns	100 – 125 mA	800	80 – 100 kW
WRN TGT 4	H^-	≤ 100	625 ms	1 mpulse / 1.8 ms	≤ 2 mA	800	< 1.6 kW
UCN	H^-	20	625 ms	Highly variable	< 5 mA	800	< 4 kW
pRad	H^-	~ 1	625 ms	60-ns / 1 ns	< 1 mA	800	< 1 kW
IPF	H^+	≤ 100 pulsed	625 ms	NA	≤ 250 mA	100	< 25 kW
Area A (inactive)	H^+	≤ 100	625 ms	NA	1000 mA	800	~ 800 kW

The LANSCCE Proton Ion Sources

H⁺ Source — Duoplasmatron

- Originally designed for high-current proton delivery
- Produces **protons (H⁺) directly**
- Accelerated from ~750 keV injector
- Originally delivered beam to **Experimental Area A**
- Since ~2000 upgrade, primarily serves the **Isotope Production Facility (IPF)**
- Robust, high-brightness DC arc discharge source
- Simple beam physics (no charge stripping required)

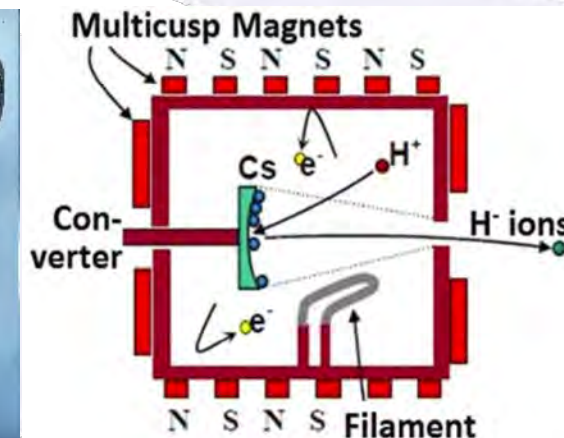
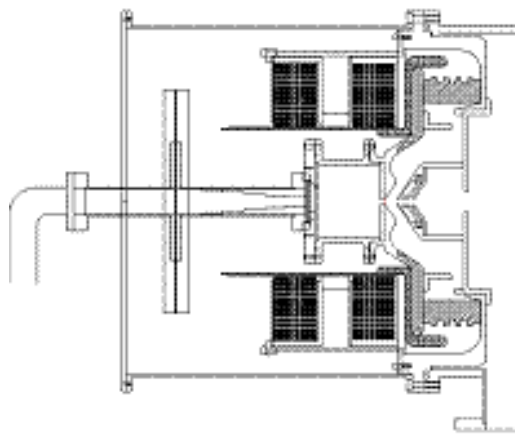
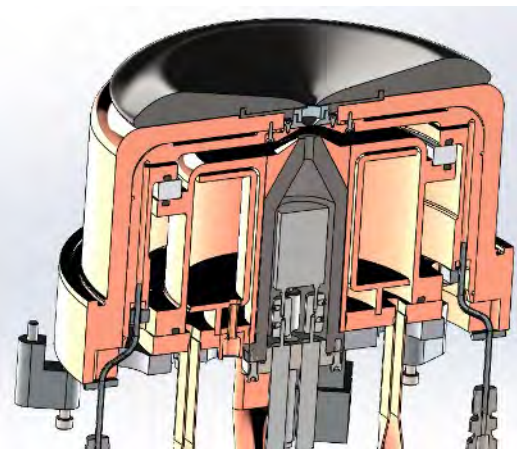

H⁻ Source — Negative Hydrogen Source

- Primary source for 800 MeV accelerator operation
- Produces negative hydrogen ions (H⁻)
- Accelerated through the full 800 MeV linac
- Primary use:
 - Injection into the Proton Storage Ring (PSR)
- Also feeds:
 - Lujan
 - WNR
 - pRad

H⁻ and H⁺ Beam Injection

- The LANSCE front-end section includes two independent injectors for H⁺ and H⁻ beams
- Each injector includes a 750 kW Cockcroft-Walton generator
- The low-energy transport (LEBT) for each beam species include a pre-buncher for modulation of the DC beam
- The H⁻ beam includes a low-frequency buncher for compression of multiple pulses into the RF structure of the accelerator
- Currently only the H⁻ beamline has a chopper for multiple user facilities
- The lines are merged just before entrance to the 205.25 MHz drift tube linac (DTL) where they are first conditioned by the main buncher

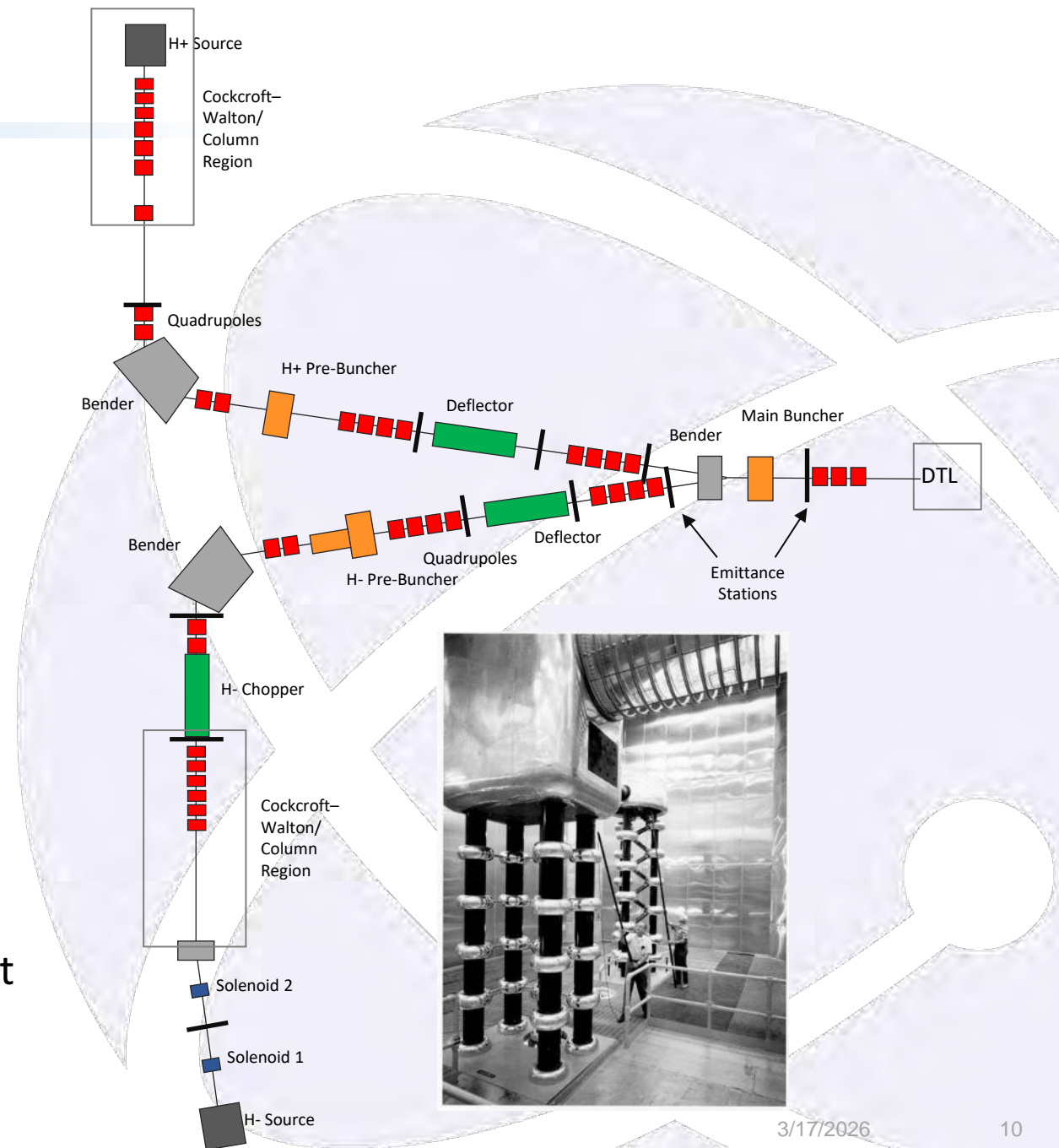

Drift-Tube Linac (DTL)

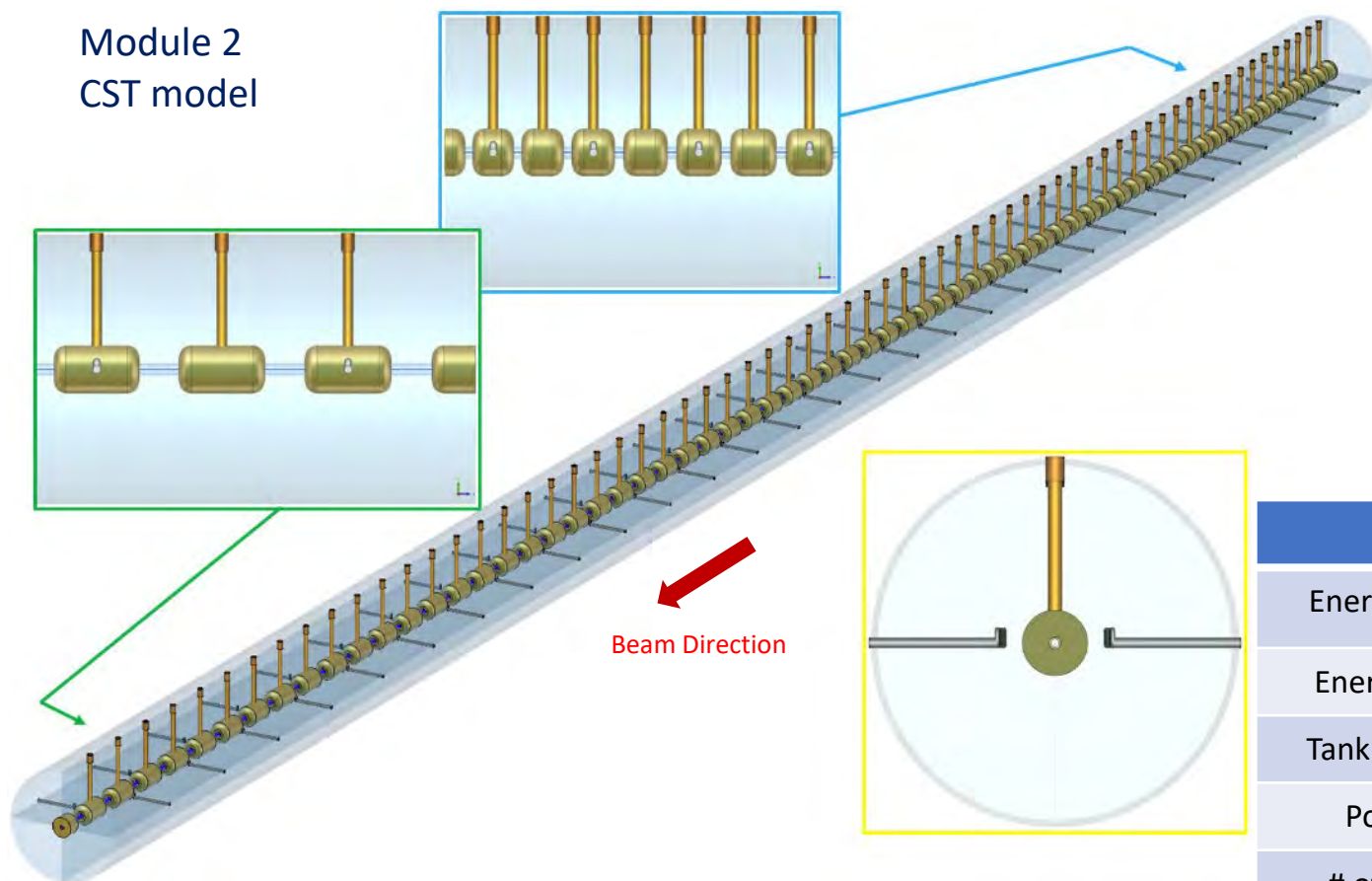

Image from Sergey Kurennoy

- The H^- and H^+ beams are matched from the LEBT into the DTL accelerator
- The DTL accelerates the 750 keV beams up to 100 MeV
- There are 4 DTL modules with differing lengths and cell dimension

	Tank 1	Tank 2	Tank 3	Tank 4
Energy gain	4.64 MeV	35.9 MeV	31.4 MeV	27.7 MeV
Energy out	5.39 MeV	41.3 MeV	72.3 MeV	100 MeV
Tank Length	326 cm	1969 cm	1875 cm	1792 cm
Power	0.305 MW	2.697 MW	2.74 MW	2.67 MW
# of cells	31	66	38	30
Bore Radius	0.75 cm	1 - 1.5 cm	1.5 cm	1.5 cm

Side Coupled-Cavity Linac (CCL)

- Various types of CCL (see below) are used at relatively high velocities, typically for $\beta \geq 0.4$
- Los Alamos National Laboratory designed the side-coupled cavity concept, first seen at LANSCCE (LAMPF)
- Energy range from 100 to 800 MeV, with final $\beta \geq 0.84$
- High shunt impedance, with $50 \text{ M}\Omega/\text{m}$
- Possible upgrades/replacement to the CCL are still being reviewed

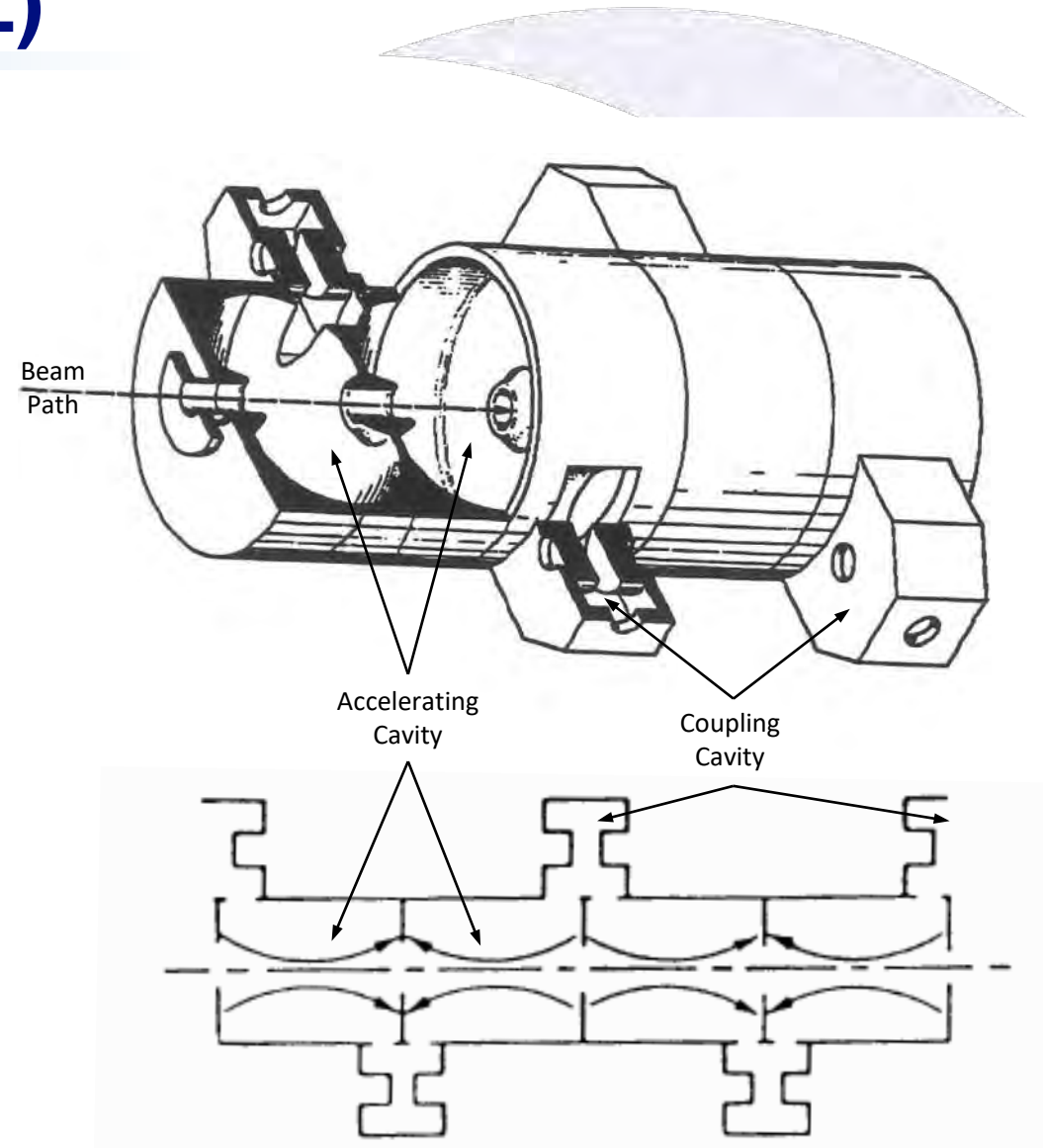
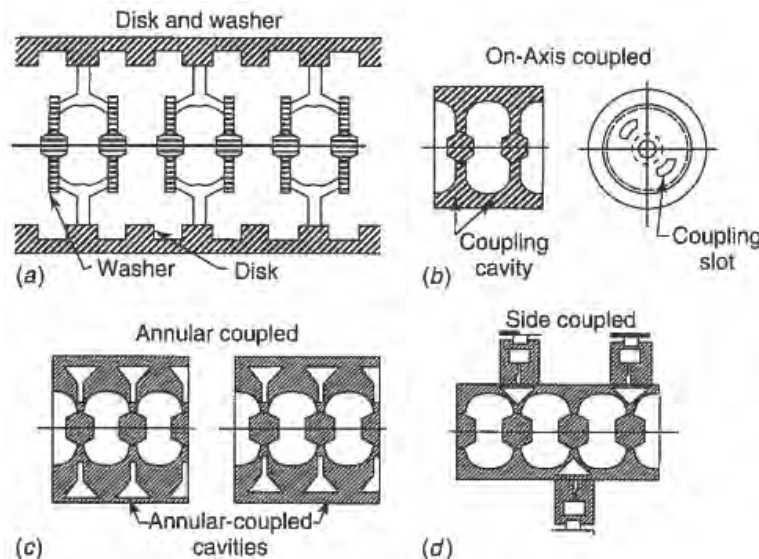

Side Coupled-Cavity Linac (CCL)

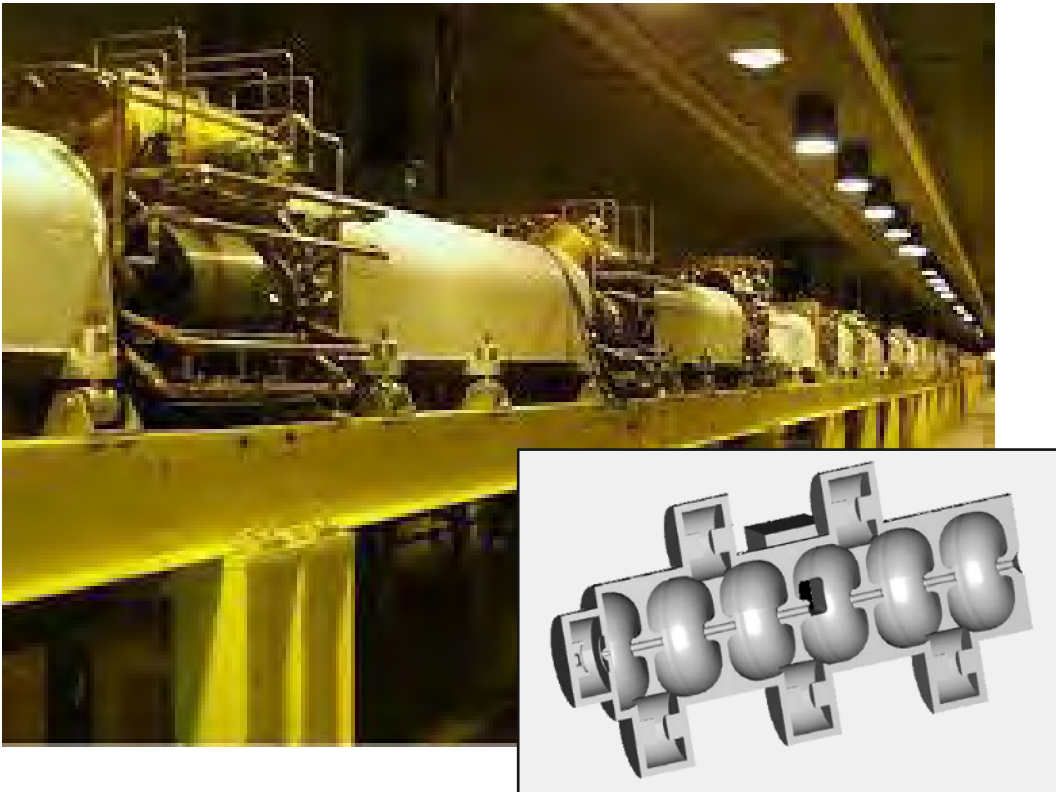

Beam energies LANSCE can provide [MeV]

211	227	241	257	272	287	303	319	334	350
366	382	398	414	431	447	464	480	497	513
530	547	564	582	598	615	632	648	665	682
699	716	733	750	767	783	800			

- Delaying a series of modules before the end of the 805-MHz CCL allows selection of proton beam energy
- For development studies, these modules were put out-of-time and beam was delivered exclusively to one facility
- Switch delay modules along the CCL enabling dual energy transport during production
 - The RF analogue system requires phase packages for time delays for specific RF gates
 - The digital system is more simplistic, only requiring simple changes to the control software for gates
- The change in magnet currents for beam transport starts with a simple momentum scaling factor

High-Energy Beam Transport (HEBT) Lines

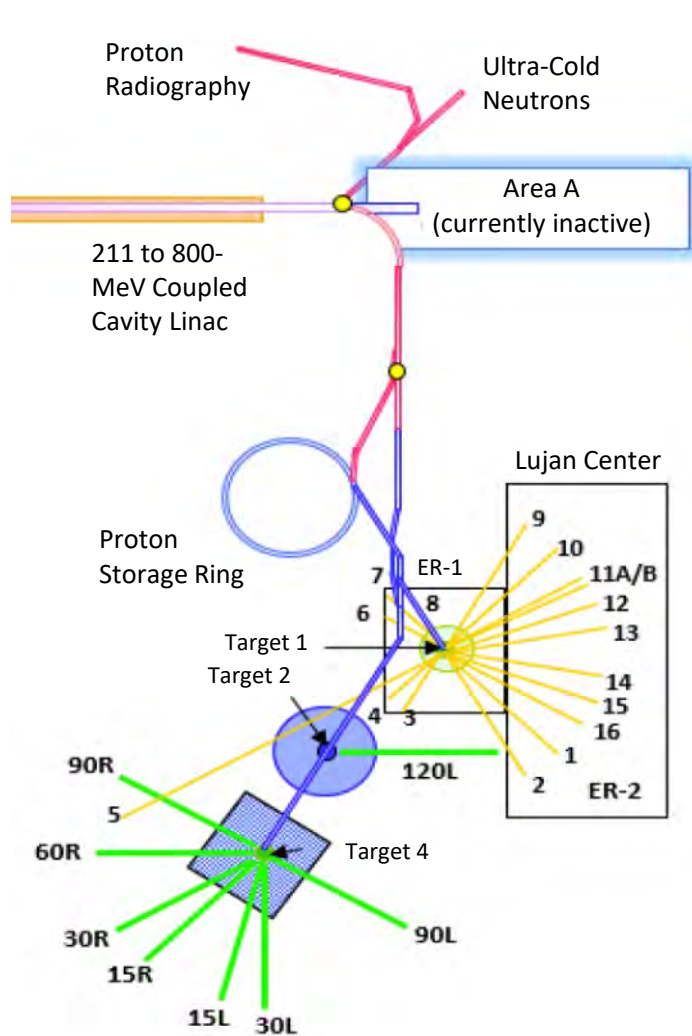

- After full beam acceleration, the beam split between transport beamlines to the north and south
- South Transport Lines (line D and RI line)
 - Beam is delivered to the south experimental facilities
 - Line D splits 20 Hz of the beam to the PSR for beam accumulation to the Lujan Center
 - The remaining 100 Hz is sent to bypass line onward to the WNR facility
- North Transport Lines (line X, B, C)
 - A pair of fast kickers are used to deflect low intensity proton beams to the north experimental halls
 - These low intensity beams facilitate studies at UCN (line B) and pRad (line C)
- East Transport Line (line A)
 - Sole delivery for high intensity H⁺ beam (1 mA average current) to experimental A

High-Energy Transport Lines

- The switchyard kicker system after the CCL splits the beam for capture into the separate beam paths
- The blue path represents the default path of the beam
- When the fast kickers fire, a small bump is applied to the beam
- The subsequent bending magnet and kicker put the beam back onto its original trajectory

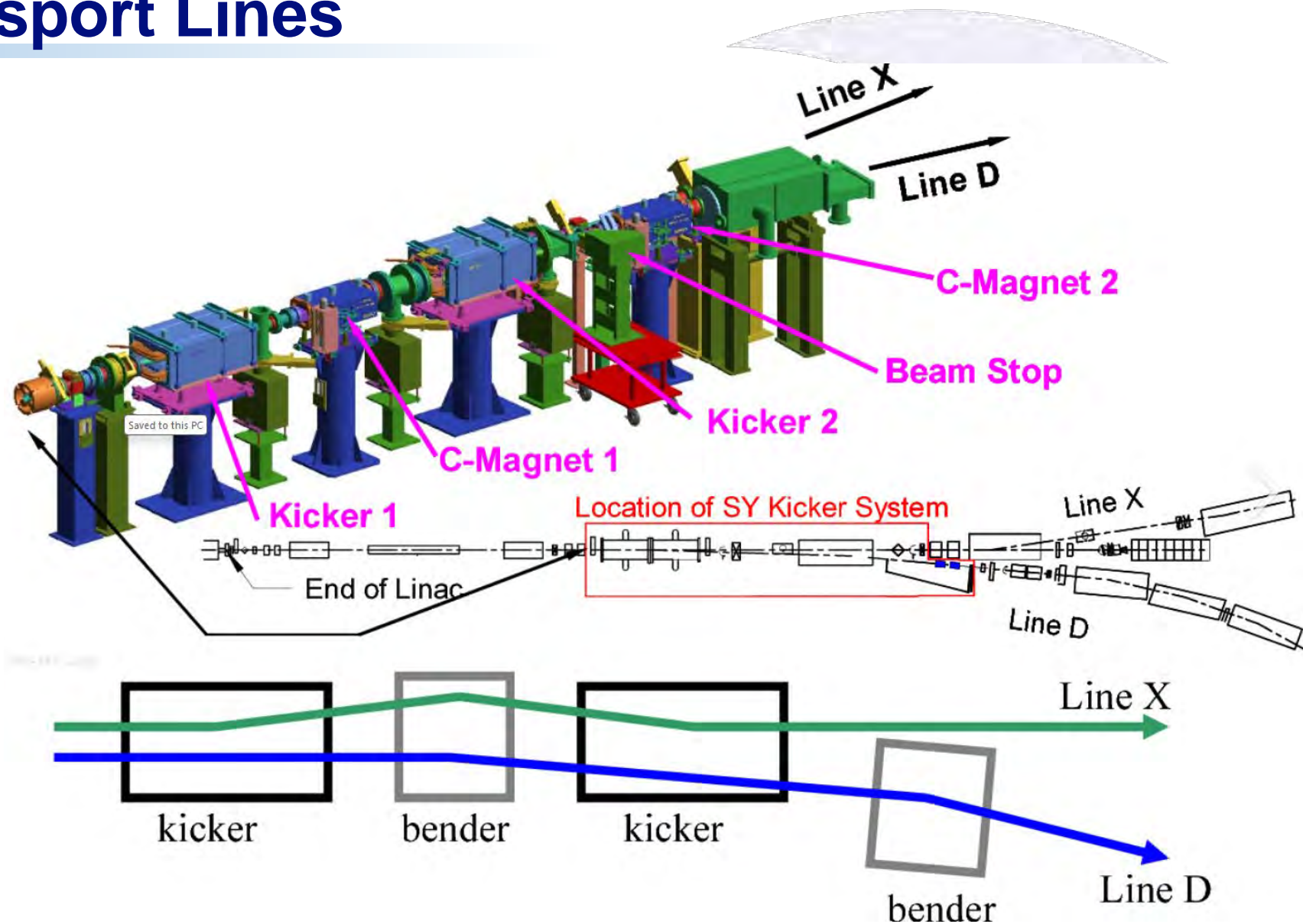

Proton Storage Ring (PSR)

- The LANSCE Proton Storage Ring (PSR) accumulates protons from a 625 μ s pulse into a more intense 300 ns beam pulse.
- Beam comes in from the transport lines as H-beam.
- A foil strips the electron, injecting the protons into the ring.
- The 625 μ s beam structure is turn-by-turn stacked on top of the previous 290-ns beam bunch (referred to as the accumulation of beam).
- As the beam is circulated, it is bunched by the harmonic buncher
- After full accumulation, the beam is extracted in one turn to the beamline for the 1L target

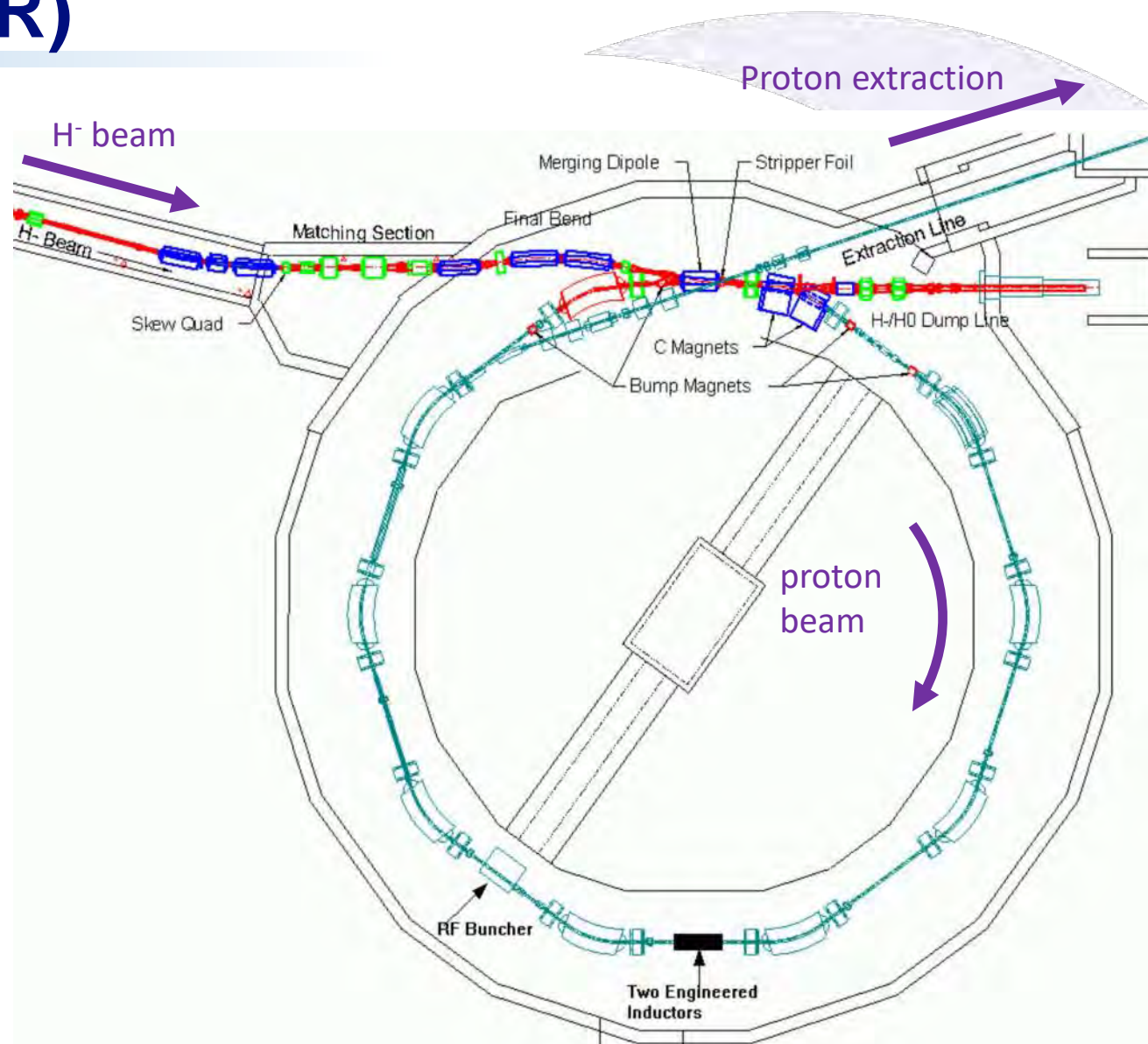

What is an Accumulation Ring?

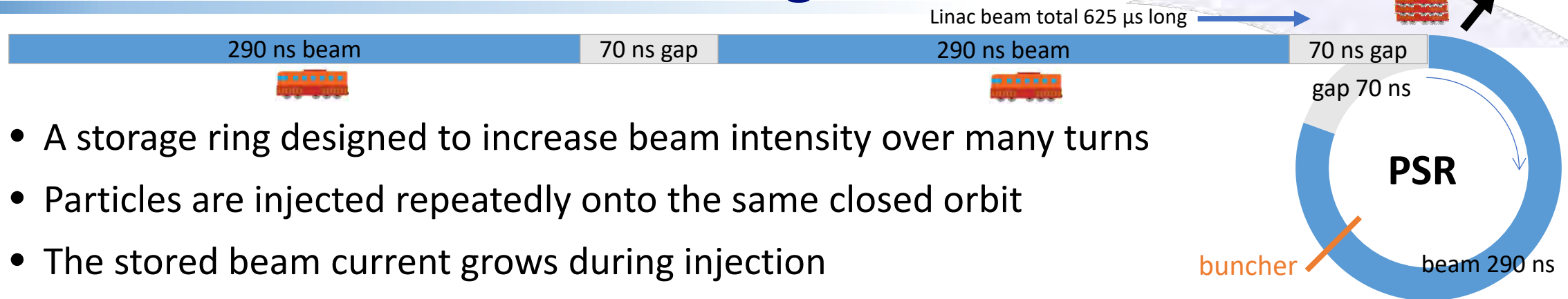

- A storage ring designed to increase beam intensity over many turns
- Particles are injected repeatedly onto the same closed orbit
- The stored beam current grows during injection
- Emittance and beam quality must be preserved during stacking
- Injection, not storage, becomes the dominant challenge
- Phase space painting becomes a critical method for space charge reduction

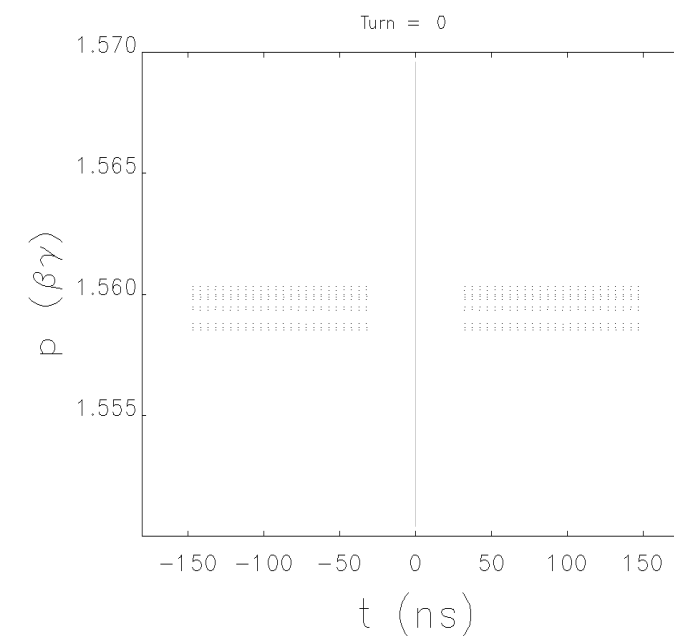
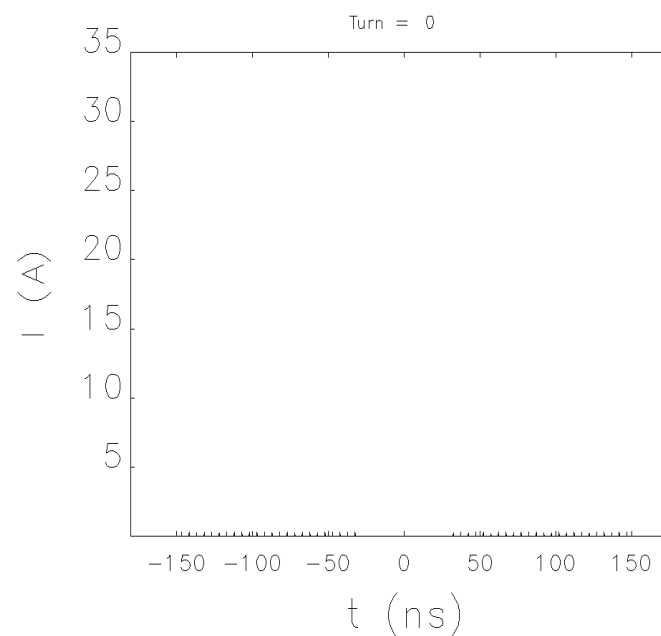

Tuning Methods

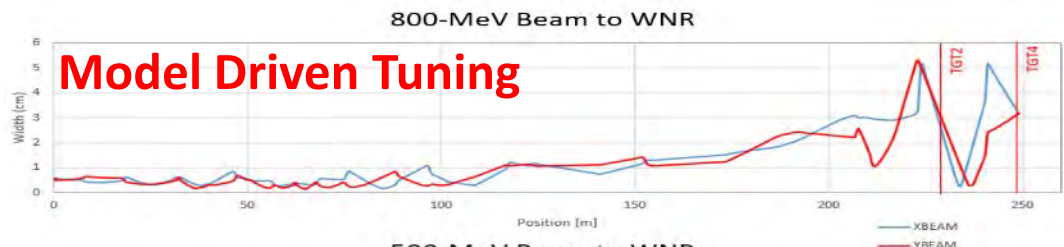

Model Driven Tuning

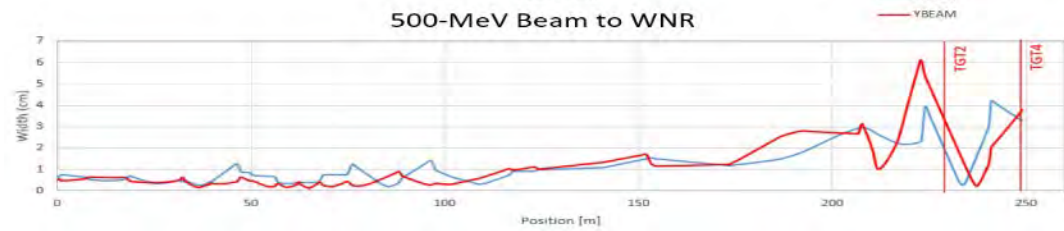

Model Independent Tuning



- There are two primary categories for beam tuning
 - *Model driven*
 - *Model independent*
- **Model driven** methods are used for the initial tune of an accelerator, such as;
 - Initial optical transport tune of the low-energy beam transports (LEBT) [Developed new cTrace and Rmatrix codes]
 - Beam capture and acceleration of the radio-frequency modules
 - Energy matching and bunching within the accumulation and acceleration rings [New ring tuning software called "RingTune"]
- **Model independent** methods dominate the optimization of an accelerator tune, like;
 - Optical element corrections to reduce beam loss in the accelerator
 - The steering of beam in the transport lines to reduce beam loss
 - Optimization of all component parameters to improve average beam current delivered to the target facilities
- Both categories of tuning could be automated

Tuning Strategies

- There are two primary strategies for both model driven and independent methods:
 - Beam **Acceptance Tuning**
 - **Adaptive Tuning** for desired performance
- Most of LANSCE's recent *automation* efforts are centered around the automation of the model independent methods
 - Adaptive tuning for reduction of loss and increased current [Badger is the most recent tool we are employing]
 - Machine Learning for system responses [LDRD-DR funded]
 - Accelerator alarm system based on analysis with neural network applications [Created new *Blameit* software]
- Preliminary results have already shown promising results
- We are now building new models and applications for assisted and/or automation of model centric tuning



A. Scheinker, EC Huang, and C. Taylor. "Extremum Seeking-Based Control System for Particle Accelerator Beam Loss Minimization." *IEEE Transactions on Control Systems Technology* 30.5 (2021): 2261-2268.

Tuning of the Transport Lines: Acceptance Tuning

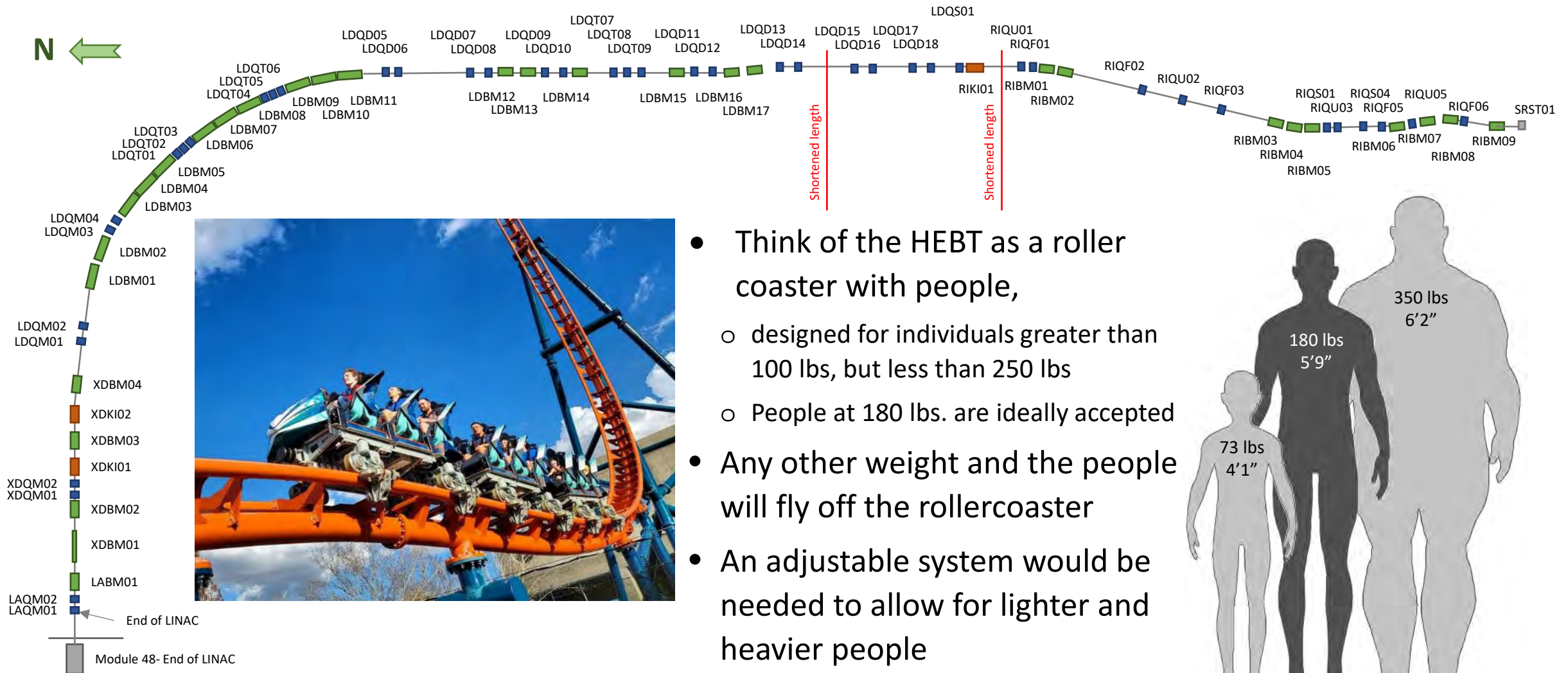

Tuning of the Transport Lines: **Adaptive Tuning**



- If we instead regulate the transport system instead of the input source, we can perform *adaptive tuning* to reduce beam loss
- Now imagine the transport as a laser transport through a pinball machine
 - Angle varies mirrors are tilted (top)
 - Wavelengths shift, refractors are shifted (bottom)
- The rollercoaster-like *acceptance tuning* methods are ideal during reproducible run cycles
- However, with *low-energy* runs, *adaptive tuning* is essential to improve beam quality achieved with scaled *acceptance tuning*
- During this TED, we applied both methods together and successfully transported the beam

Tuning Methods for the Low-Energy Beam Transport

- The LEBT tuning depends on a source with limited reproducibility
- The use of *adaptive tuning* is necessary
- The software we developed here could be expanded to the HEBT and employs *model driven* methods

The screenshot shows the RMatrix software interface. At the top, it displays the beamline name '69 - TAFJ03' and '106 - BLZ RFFACEOFMODUL...'. Below this is a table of beamline elements with columns for Element, Length, X, X', Y, Y', Alpha X, and Beta X. The table lists elements from 69 to 74, including TAFJ03, DELTA4, DRIFT, and TAQL8V1. To the right of the table, there are several plots: a phase space plot (Angle vs Position) showing beam envelopes, a longitudinal profile plot (Profile vs Length), and a plot of X and Y positions vs Angle. At the bottom, there are control panels for 'Gate' and 'Strip' with various parameters like Rep Rate, Delay, Length, and Mode.

This screenshot shows a terminal window displaying fitting parameters and target data. The text includes 'Setting target Twiss at element 135: BLZ_RFFACEOFMOD.1..75CMRAD.APER.', 'Twiss Targets:', and 'Round Targets:'. It lists parameters for elements 132 through 148, including PA-BAPT, DELTA-T, and DRIFT. Below this, there is a table of fitting parameters with columns for element, x, y, x', y', and z. The table lists elements 145 through 152.

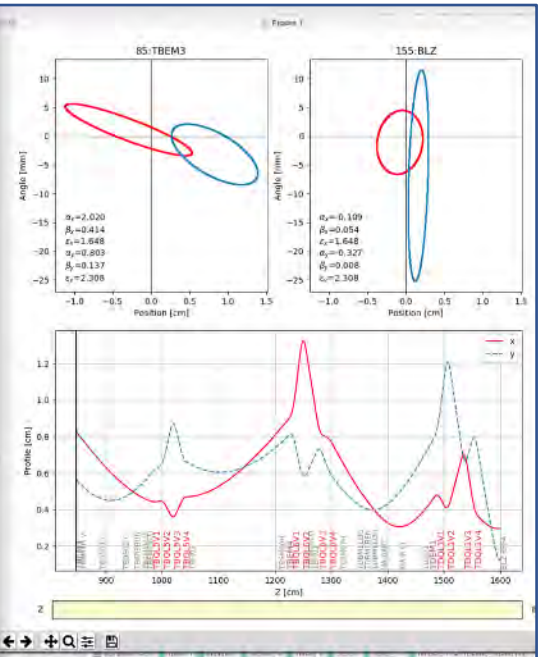

↑
cTrace: Huang's conversion of Fortran code to C++
 ←
RMatrix: Taylor's user interface for cTrace tuning

Side Coupled-Cavity Linac (CCL)

- Digital RF system upgrades from old analogue systems
- Beam Position and Phase Monitor (BPPM) upgrades
- More accurate beam energy measurements
- Modernized method for tuning the CCL modules
- Working on refinements of the data acquisition system
- Develop adaptive tuning methods for improved tuning and operation

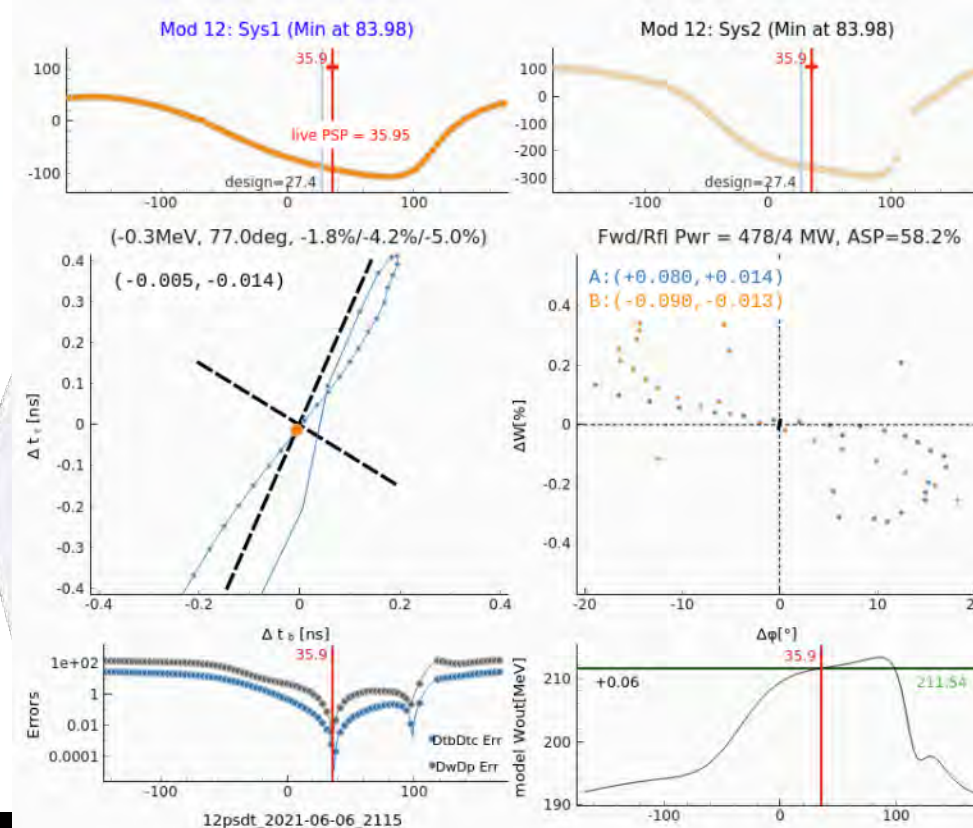

Phase ΔT program

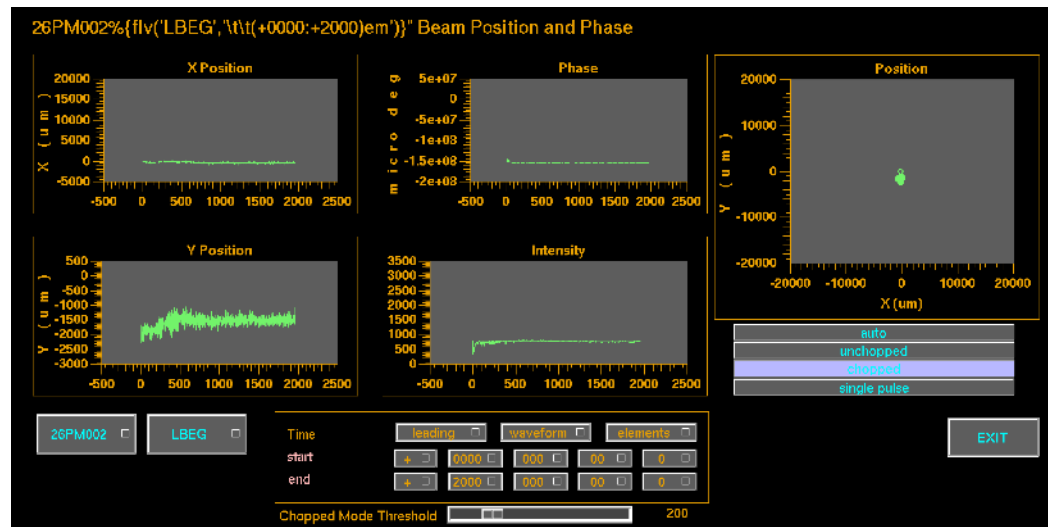

BMMP Program

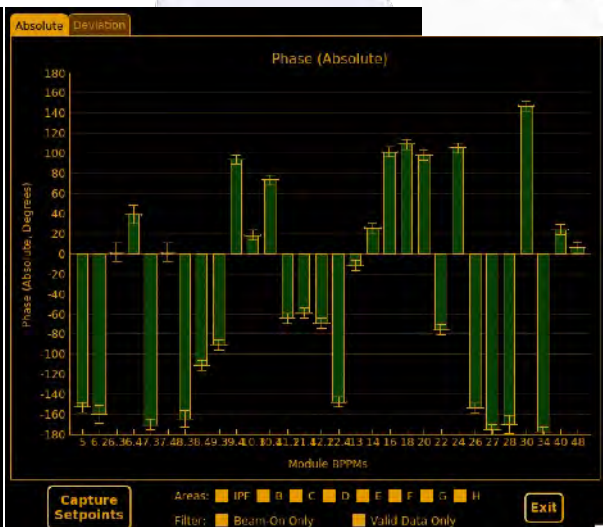

Tune lurch monitor

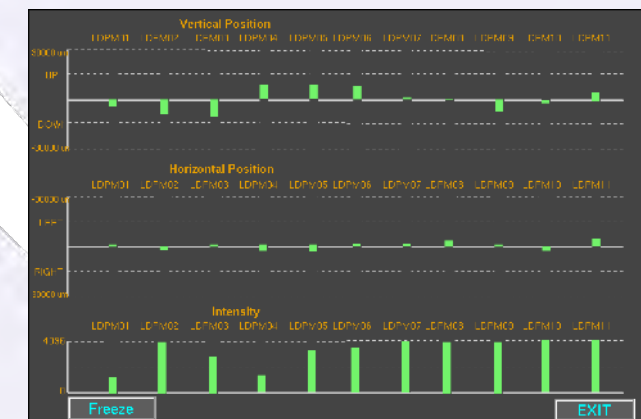

Beam Position Bar

HEBT Simulation: Acceptance Tuning

LANSCE Phase II Upgrade Technical Design Report - Chapter I - Draft of 7/26/96

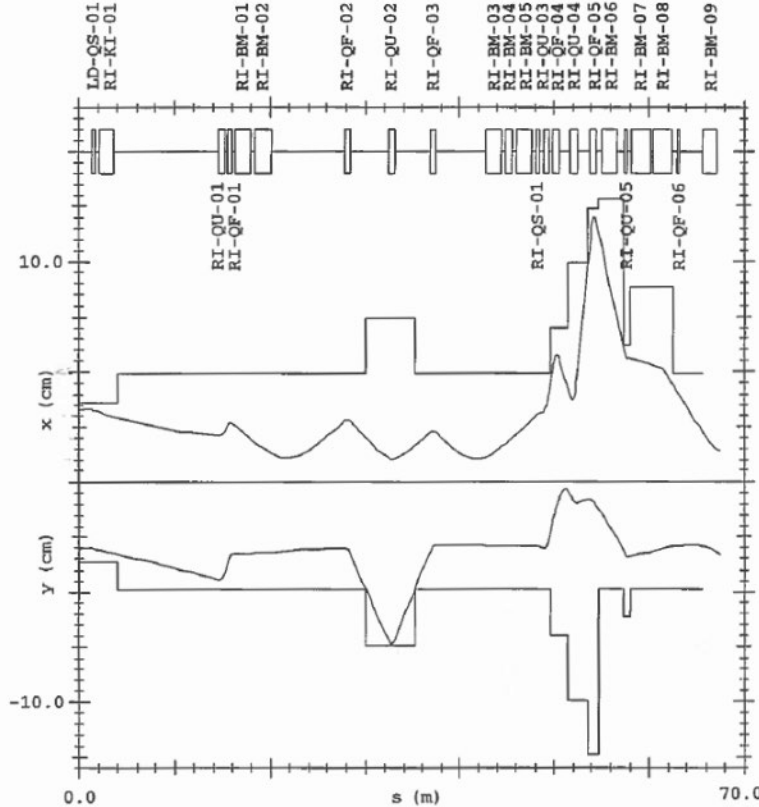
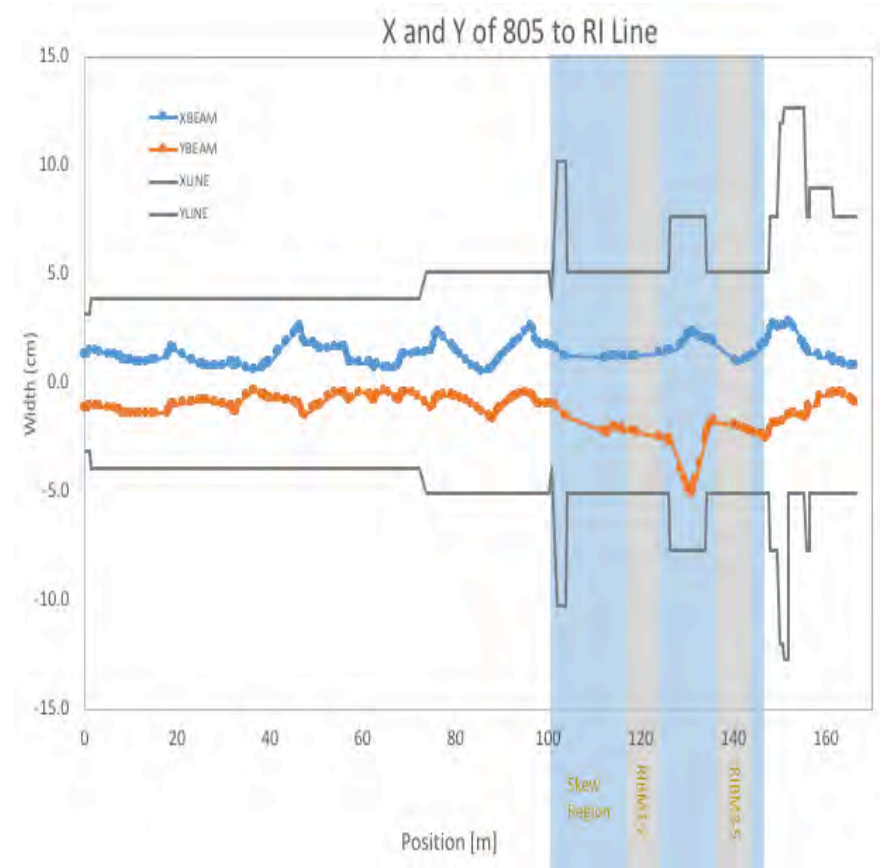

Figure 8. Horizontal and vertical beam envelopes for 6.6 times the rms size of the beam with RMS emittance of 0.08 π -cm-mrad and the size due to a momentum spread of $\pm 0.5\%$ added linearly. Also shown are the locations of the magnetic elements and the horizontal and vertical inside dimensions of the pipes throughout the injection line. In the skew bend, the beam envelopes and apertures are those in the skew plane. In the last bend, the envelopes have added to them the beam-centroid shifts for horizontal on-axis injection and vertical steering to the injection point.

Original Design RI Line model

- We start with scaled *Acceptance tuning*
- The beam acceptance can be calculated by finding the point at which the emittance increase causes the beam to touch the side of the beam line
- In 2021 (right), the beam RMS does a much better job of staying within the confines of the beam pipe dimensions when compared with the initial design parameters (left)

2021 Horizontal and vertical beam envelopes for 6.6 times the RMS size, from the end of the LINAC to the point of ring injection.



Current RI Line model

HEBT Simulation: Adaptive tuning and Optimization Visualization



- RMatrix has also been developed to use the TRANSPORT/madx/Elegant optics codes
- This mode includes two modes of operation:
 - Tuning match for beam parameters
 - Optimization Visualization
- The visualization reads the magnets real-time and allow the operator see the changes in the beam envelope
- The Rmatrix is ready to be used for the LEBT startup this year
- The HEBT method will need more time in testing to validate results

LANSCCE DTL Complications

- The LANSCE drift tube linac has been accelerating protons for 54 years
- In 2019, the third module in the DTL began to fail, requiring a reduction of repetition rate to 60 Hz
- After 3 weeks of investigation, a crack was found on along side the vacuum grating of the inner cavity
- Our smallest welder qualified for copper welding spent a week training in a mockup tank
- After several hours of work, the patch was finished and inspected
- Results were immediately positive, with full beam loading with no arc downs
- Increased concerns of the life of the remaining tanks of the drift-tube linac



LANSCCE H- and H+ Ion Source Complications

- H- Output and Performance Limits
 - The H⁻ ion source has provided stable beams for decades, but its maximum beam output has remained essentially constant (~14 mA) despite operational experience.
 - Efforts are underway to understand and improve this limitation because it constrains throughput to experimental areas
- H- Lifetime and Reliability Factors
 - The source is filament-driven with a cesiated surface converter — cesium is essential but complex to control.
 - Internal plasma and cesium distribution dynamics are not fully quantified, leading to operational variability.
 - Filament lifetime and degradation remain significant operational concerns because they affect uptime between maintenance cycles

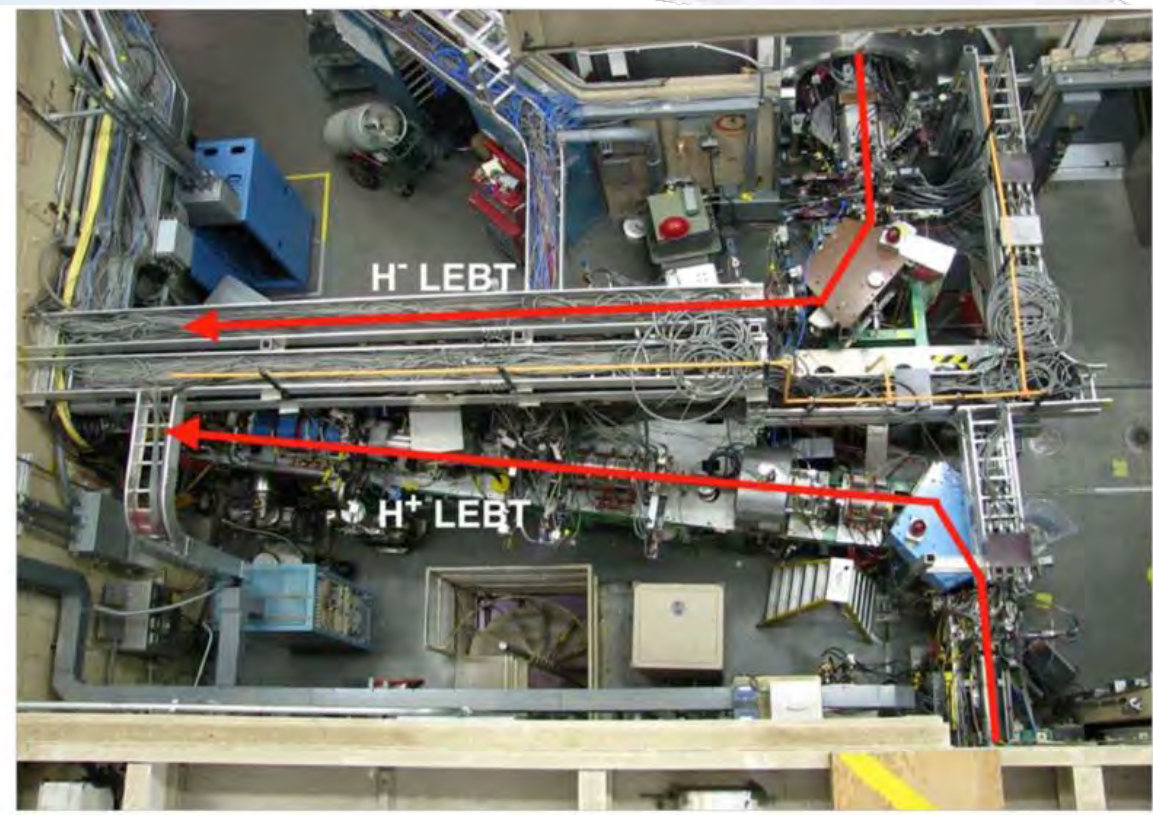

- H⁺ (Duoplasmatron) Ion Source
 - The duoplasmatron H⁺ source has shown significant signs of aging
 - Until 2023, it has been our most stable beam
 - Now it has gone through a series of system failures

LANSCCE Klystron Challenges

- High Failure Rates and Reduced Spare Inventory
- In recent years LANSCCE has experienced a significant failure rate of these klystrons, leading to:
 - Downed beam time
 - Dwindling hot spare counts
 - Increased maintenance and reliability risk
- The failures have become frequent enough that klystron availability and health are now key operational concerns
- Analysis shows newer batches of klystrons sometimes fail earlier than older ones, with a notable number failing before accumulating typical service hours.
- Common issues include vacuum leaks and electron-gun related faults.



Klystron Failures

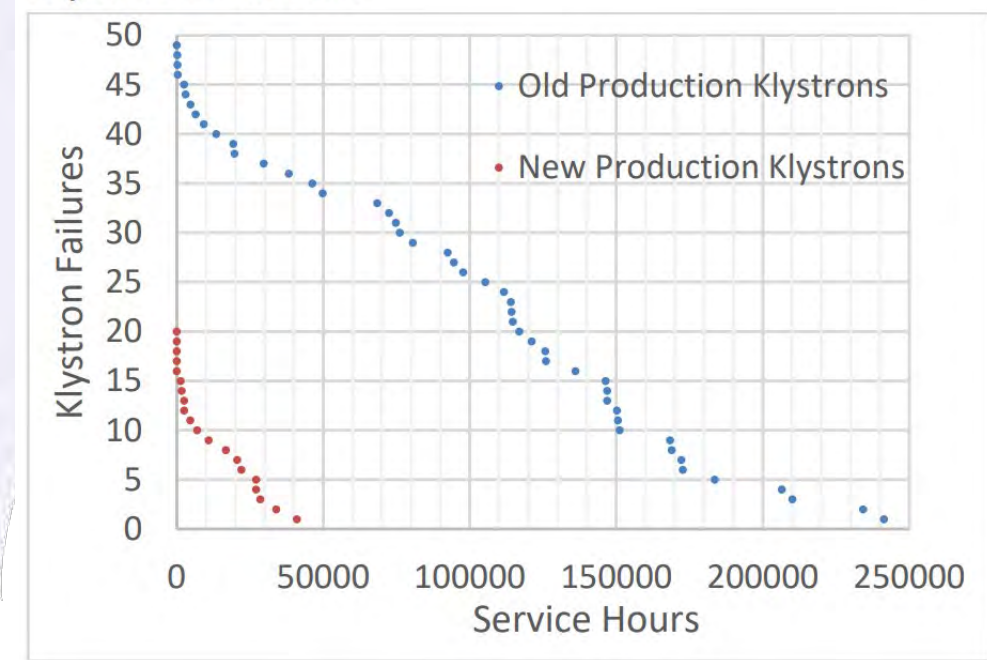

Strategic Context for LANL Accelerator Stewardship

- Los Alamos' most visible responsibilities are its current and future large accelerators
 - LANSCE – 800-MeV proton accelerator
 - DARHT – ~20-MeV single-pulse (chopped) linear induction accelerators
 - ECSE/ASD-Scorpius (2028) – ~20-MeV multi-pulse linear induction accelerator to be located at NNSS
 - DMMSC/MaRIE (late 2030s) – 12-GeV electron accelerator feeding a 42-keV x-ray free-electron laser to be co-located with LANSCE
 - Advanced hydrodynamic facility – Preliminary synchrotron discussion is ongoing, but designs at LANL have been explore for the past three decades
- We have a clear sense of our strategic priorities for the next generation of stockpile stewardship
 - We must steward people, facilities, and research
- Accelerator capability stewardship (physics, engineering, execution/operations) is a shared responsibility
- Strengthening partnerships between facilities and projects can be mutually beneficial



LANSCCE Modernization Project (LAMP)

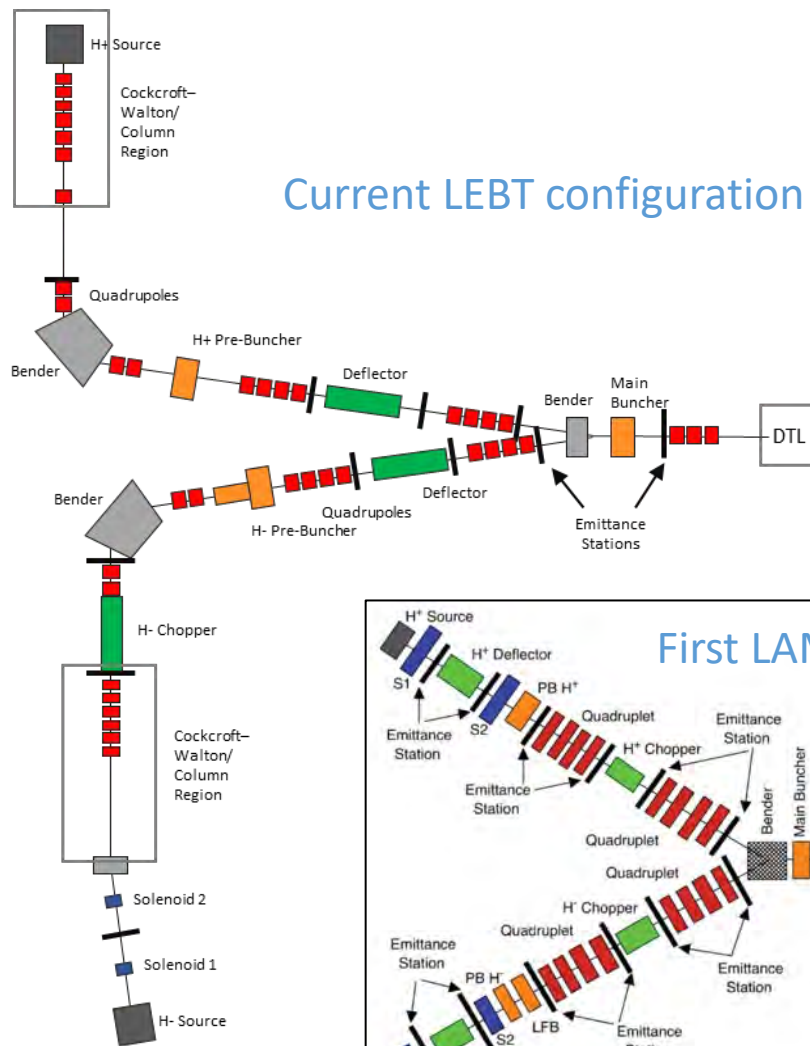

- **Modernized Ion Sources**

- Replacement of legacy Cockcroft–Walton-based injectors
- Modern H^- and H^+ ion source platforms
- Improved beam current stability and lifetime
- Enhanced control of plasma and extraction conditions
- Designed for higher reliability and maintainability

- **New Low Energy Beam Transport (LEBT)**

- Unique dual species RFQ acceleration/bunching
- Optimized matching into the RFQ
- Modern focusing solenoids and steering elements
- Integrated beam diagnostics (current, profile, emittance)
- Fast beam protection and chopping capability
- Improved space-charge control at high current
- The LEBT defines beam quality before RF acceleration

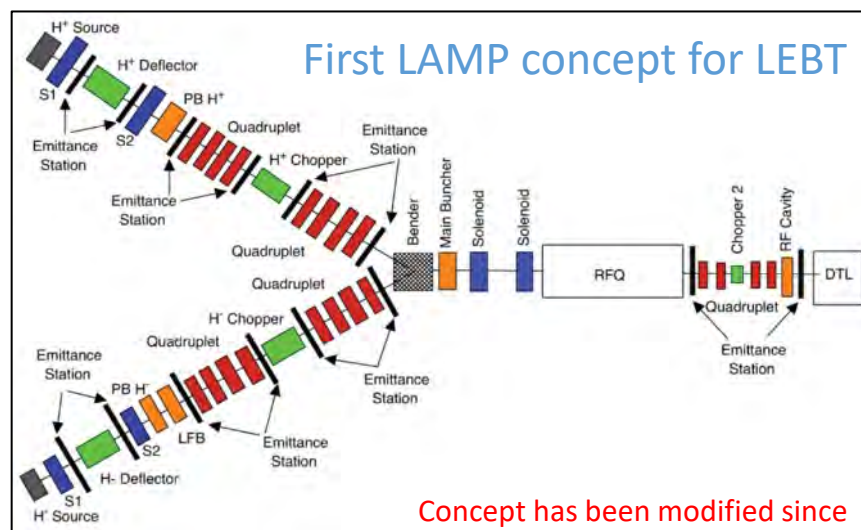

Concept has been modified since

LANSCCE Modernization Project (LAMP)



Layout of the new RFQ-based 3-MeV injector.

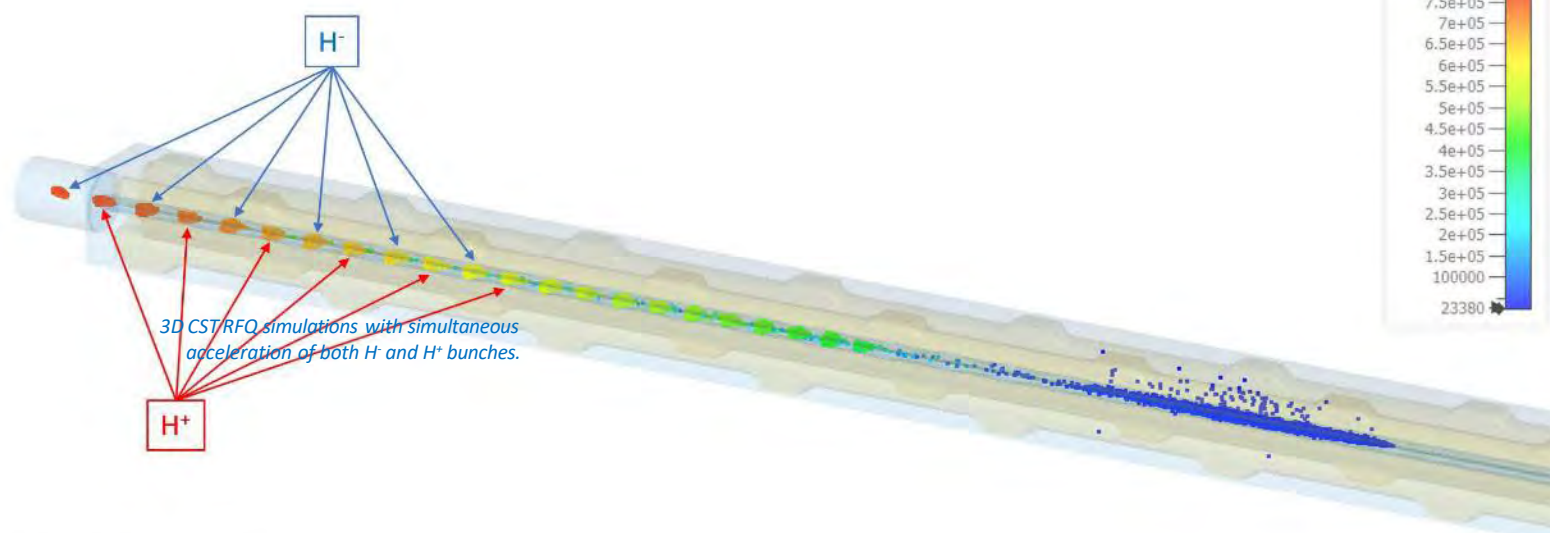

LAMP
LANSCCE MODERNIZATION PROJECT

**Start-to-end simulation
for LAMP front-end
scoping studies**

S. Sosa, D. Gorelov, S. Kurennoy,
J. Upadhyay, E. Henestroza

LA-UR-24-21709
February 14th, 2021

position monitor 1	
Output	Energy
Sample	406/475
Time	405 ns
Particles	186715
Maximum (Sample)	787920 eV
Maximum (Global)	802079 eV

LAMP Preliminary Engineering Design

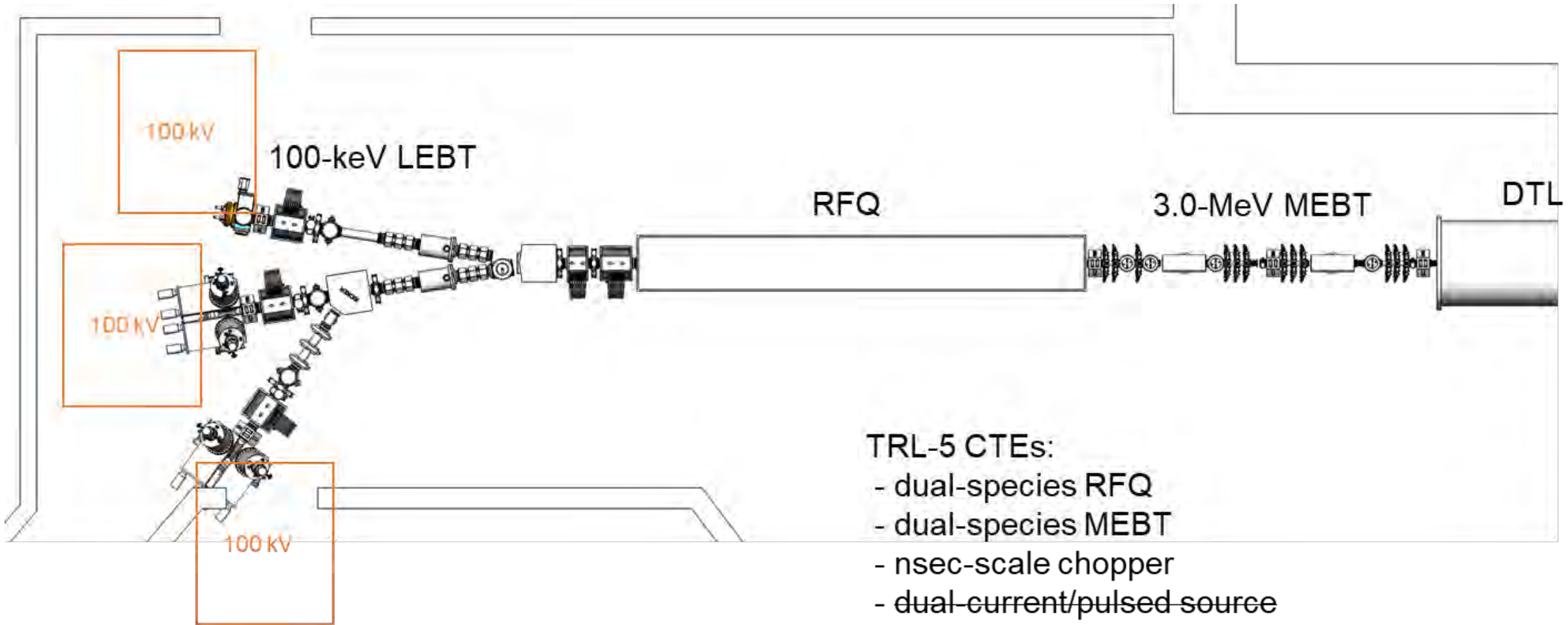

- TRL-5 CTEs:
- dual-species RFQ
 - dual-species MEBT
 - nsec-scale chopper
 - dual-current/pulsed source
 - 100-keV H⁻ source (!)

Preliminary Simulations of the LAMP Components

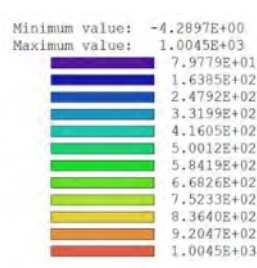
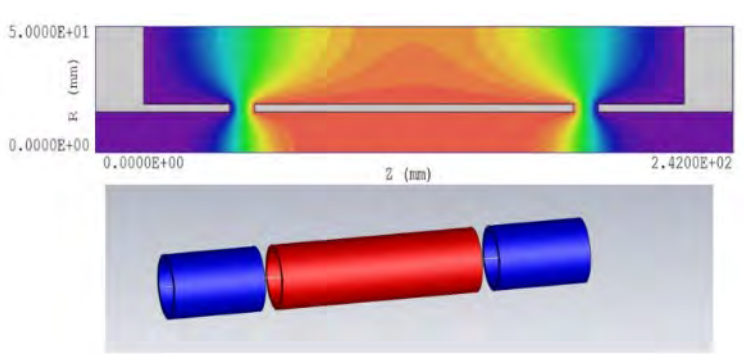
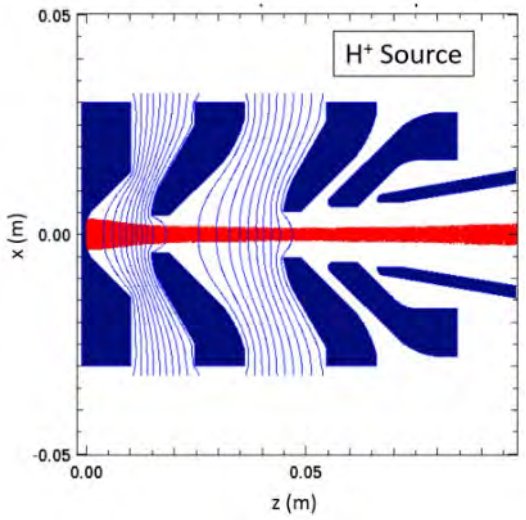

Model of low-frequency buncher for LAMP (16.67 MHz), re-designed for 100keV H- beam, [J. Upadhyay]

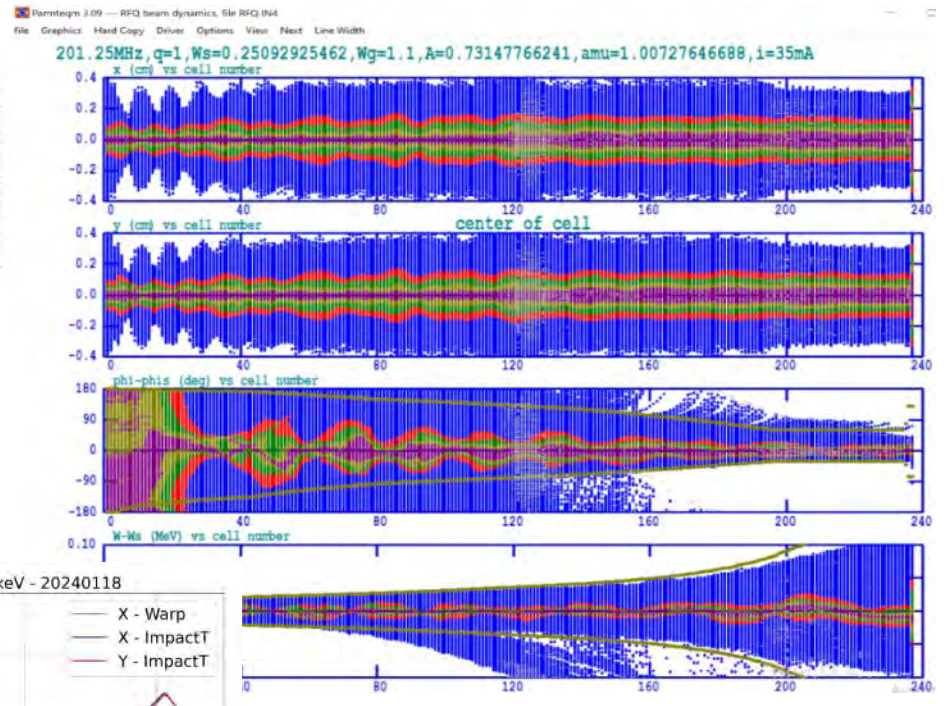

A transverse cut showcasing the model of the H+ source in Warp [S.I. Sosa Guitron]

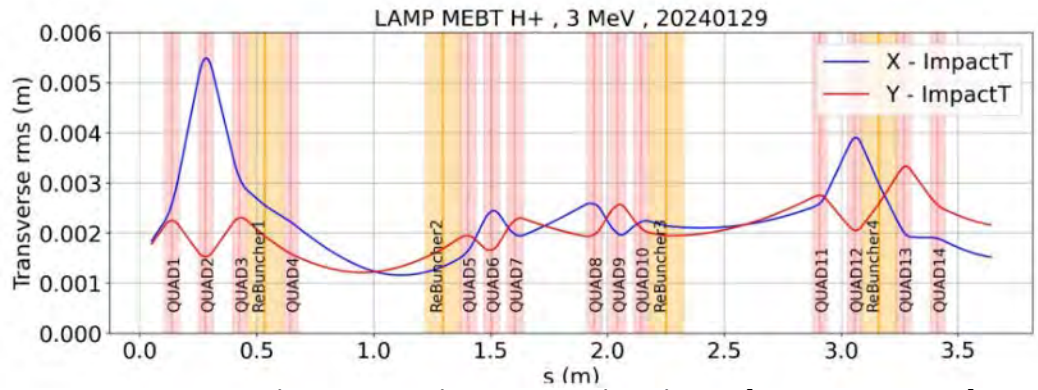

Transverse dynamics in the MEBT with H- beam [S.I. Sosa Guitron]

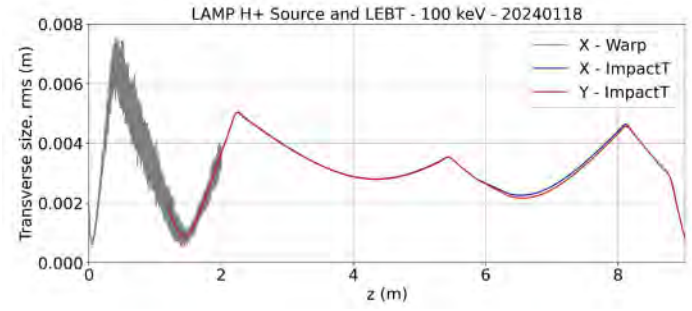

shows the longitudinal rms size as the initial beam is compressed with the LFB at z= 4.2 meters for MPEG-like beam [S.I. Sosa Guitron]

The handshake between the RFQ and MEBT simulations. At the top, H+ beam at the end of the RFQ as calculated by Parmteq, at the bottom, the input beam read by Impact-T for the MEBT simulation. The RFQ was designed to output the same phase space distribution for both H+ and H- beams into the MEBT. This way, the MEBT can transport both species of beams

Preliminary Analysis of Pulsed-Electrode Focusing

H- source current: switching between 16-mA mode and 45-mA mode.
 100% duplicate of SNS LEBT geometry.
 Electrodes are pulsed, with different voltages for shaping Lujan / WNR beam.

Lujan:

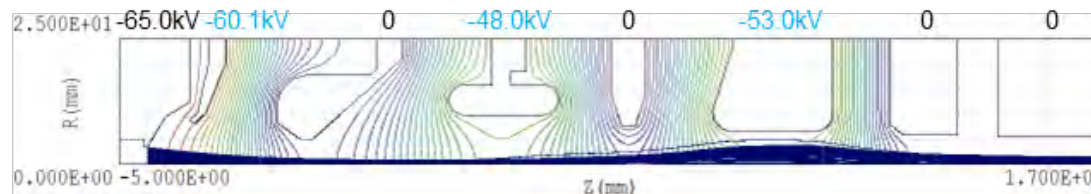

Lujan		$\alpha_{x/y}$	$\beta_{x/y}$ [cm/mrad]	$\epsilon_{rms,x/y}^N$ [π -cm-mrad]
LEBT exit / RFQ entr.	16.1 mA	0.463	0.00729	0.00927
RFQ exit	99.5% trans.	0.377 / -0.911	0.0129 / 0.0302	0.0225

WNR:

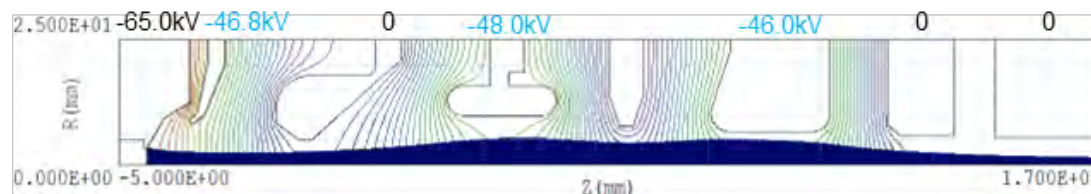

WNR		$\alpha_{x/y}$	$\beta_{x/y}$ [cm/mrad]	$\epsilon_{rms,x/y}^N$ [π -cm-mrad]
LEBT exit / RFQ entr.	45.5 mA	0.785	0.00728	0.0101
RFQ exit	98.5% trans.	0.494 / -1.31	0.0174 / 0.0423	0.0222

Proton Storage Ring Future Upgrade

LA-UR-24-20198
 Approved for public release; distribution is unlimited.

Title: LAMPF/PSR Scoping Studies Report
 Author(s): Lovelace, John (Work)
 Topic: Charles Edwards
 Intended for: Report
 Issued: 2024-02-28 (rev. 1)



The Input Parameters for Ferrite Permeability

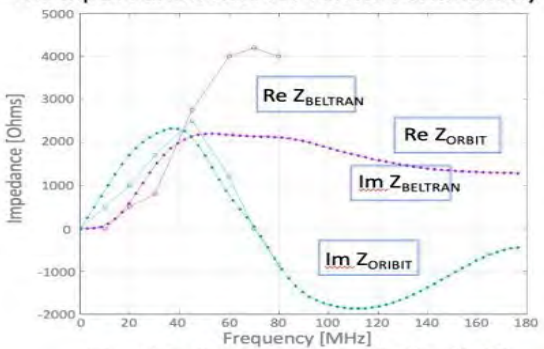

Measured Beam Accumulation (163°)

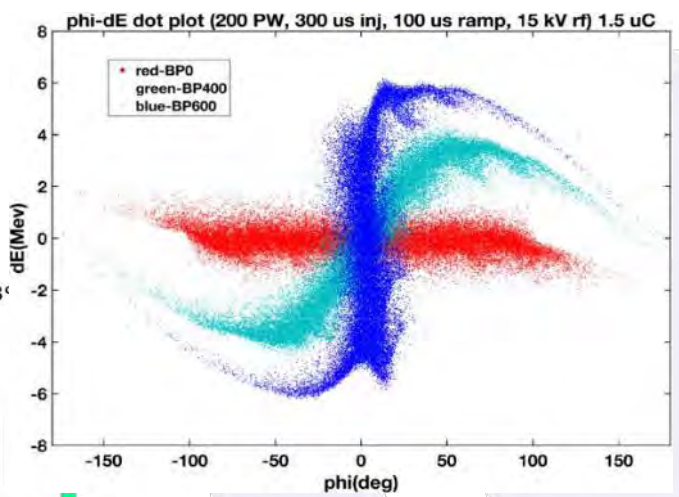
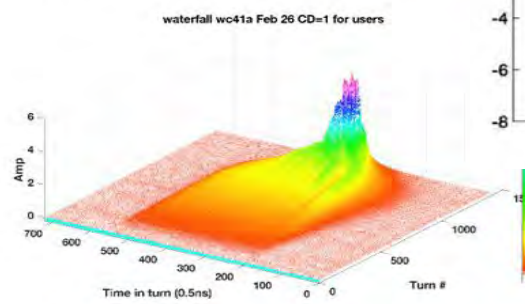

Snap-rotation options for beam extraction

Simulated Beam Accumulation (25°)

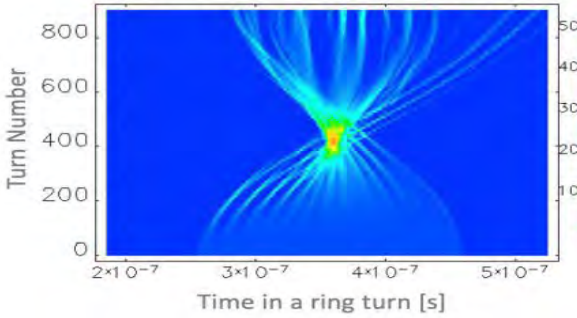

Simulated Beam Accumulation (125°)

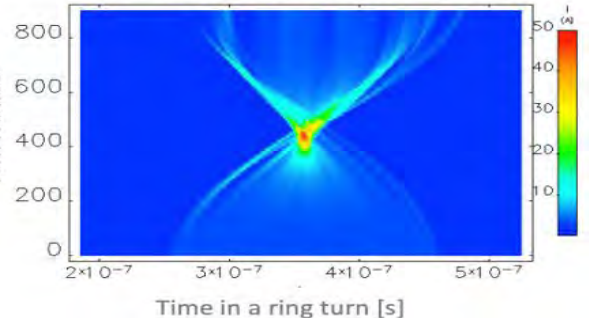

Modeling impedance-driven instability in the ring, and mitigation via ferrite inserts

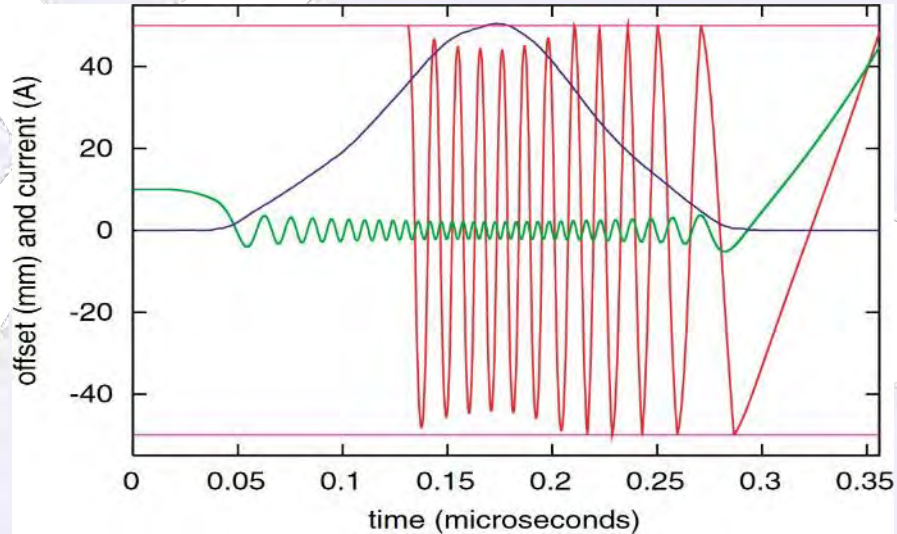

Multipacting calculations (another driver of beam instabilities)

LANSCCE Enhancement (LANE) Project

- **LAMP: Modernizing the Foundation**
 - Replaces aging front-end accelerator systems
 - Improves reliability and beam availability
 - Reduces single-point failures
 - Ensures operations through ~2050
 - Focused on sustaining existing mission capabilities
- *LAMP keeps LANSCCE running for decades to come*
- **LANE: Expanding the Mission Space**
 - LANSCCE Enhancements (LANE) initiative
 - Focused on advancing experimental capabilities
 - Driven by evolving NNSA mission needs
 - Potential expansion of:
 - Proton Radiography
 - Neutron science
 - Advanced materials diagnostics
 - Area A restoration
 - Positions LANSCCE for next-generation national security challenges
- *LAMP keeps LANSCCE running for decades to come*

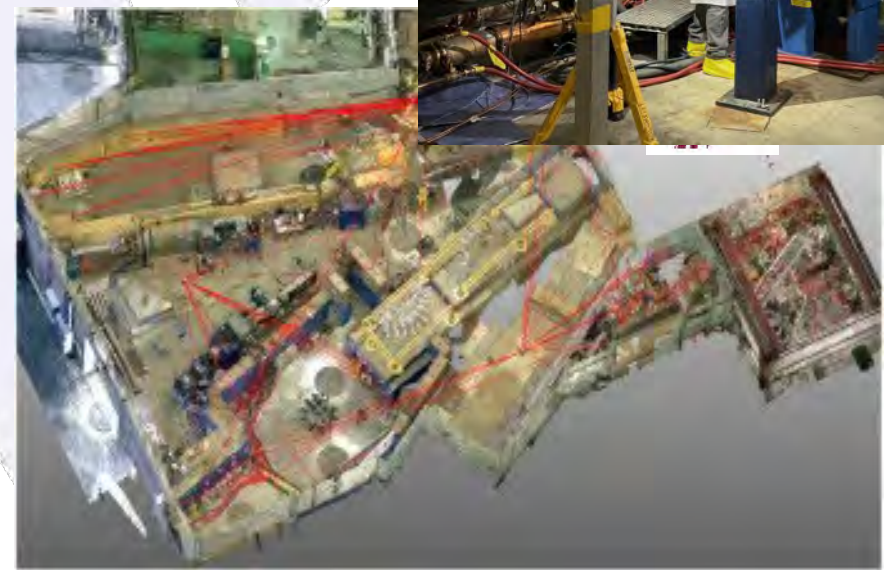

LANE proposes to update LANSCCE capability to enhance alignment with NNSA future directions

Proton Radiography (pRad Facility)

- Dynamic imaging providing focused weapons physics data for models & simulations

Lujan Neutron Scattering Center (Lujan Center)

- Materials characterization supporting aging, manufacturing, and performance as well as nuclear energy
- Nuclear physics for defense programs

Weapons Neutron Research Facility (WNR)

- Nuclear physics serving weapons assessments, counterproliferation, and criticality safety
- Electronics testing for industry and global security

Isotope Production Facility (IPF)

- Medical and other isotopes for the isotope program
- Short-lived isotopes for defense programs, non-/counterproliferation, and criticality safety

Ultra-Cold Neutron Facility (UCN)

- Unique probe for nuclear physics, possible future defense program uses



NNSA work
Key program drivers

- 100-800 MeV proton energies
- Six target stations (three neutron spallation targets)
- Sixteen beam lines (including future capability expansion in Area A)

LINAC = "Linear Accelerator"

LANE would add NNSA mission driven capabilities

Potential layout of current LANE concept

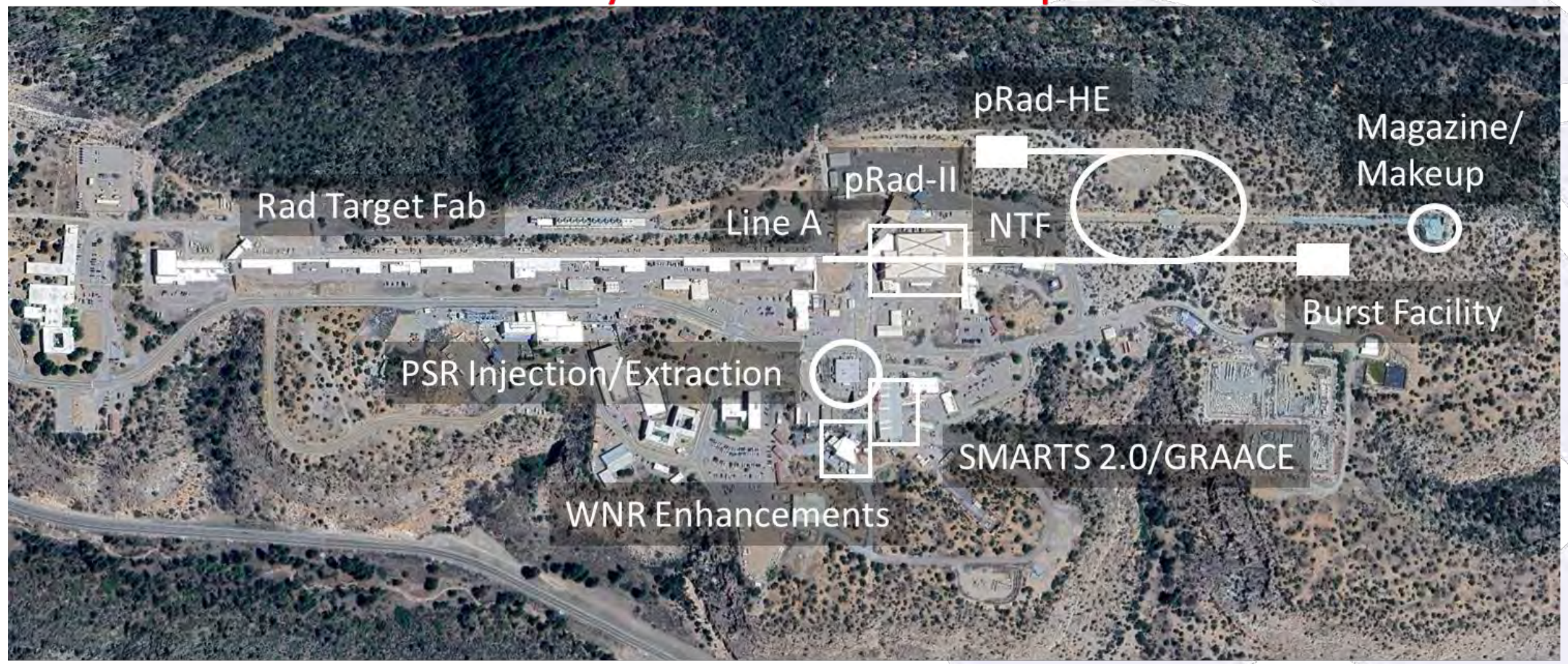

LANE uses a phased approach to implement upgrades

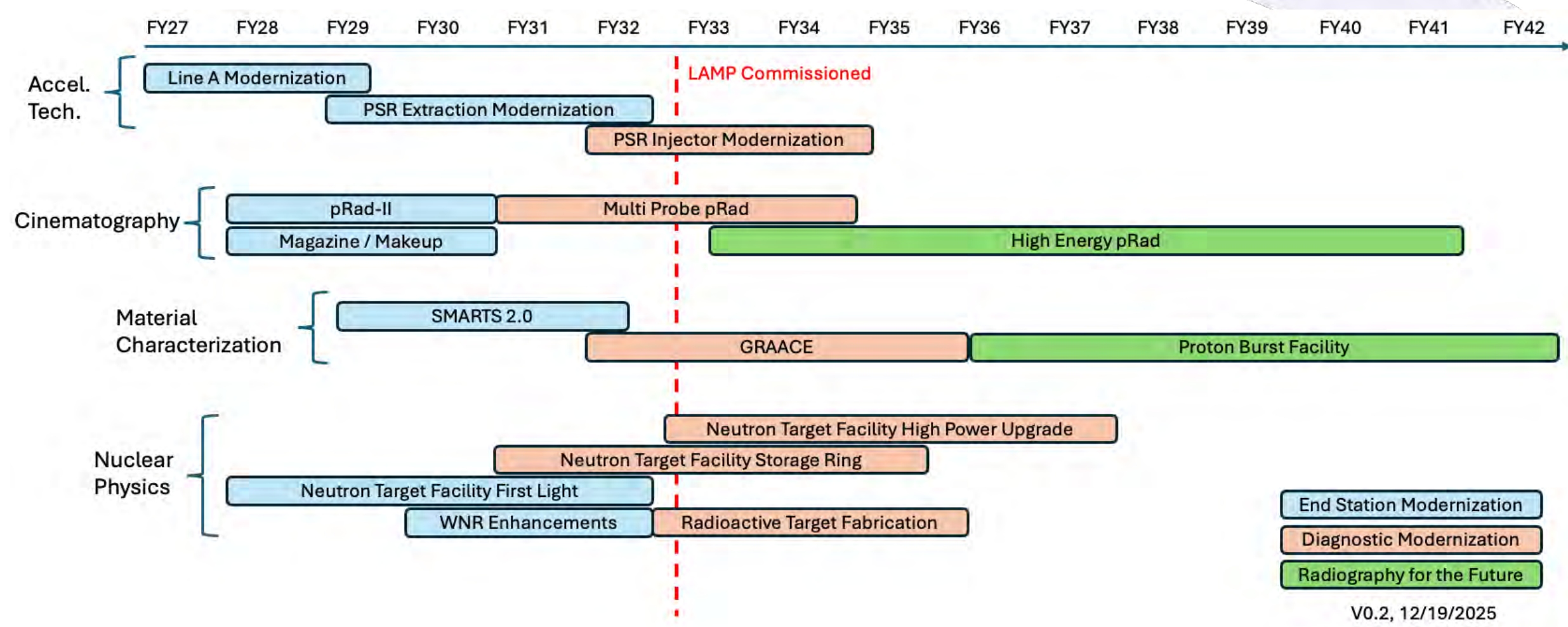

Potential enhancements in current LANE concept

Line A Modernization paves the way for LANE activities



Line A: re-introduce beam to Area A

- Currently nonfunctional
- Opportunity: restore beam delivery and build team + credibility to execute larger LANE activities



Why LANSCE is Fascinating?

A Facility With Extraordinary Scientific Breadth

- Driven by NNSA national security mission needs
- Central to the Stockpile Stewardship program
- Enables experiments that cannot be performed elsewhere

Materials Science at LANSCE Includes:

- Radiation damage and electronics aging studies
- Plutonium and uranium aging & performance
- Nuclear fuel characterization
- Additive manufacturing qualification
- Residual stress and texture measurements
- Hydrogen storage and energy materials
- Neutron diffraction and inelastic scattering
- High-explosive and structural material characterization

Fundamental Physics Programs:

- Precision neutron lifetime measurements
- Coherent neutrino studies
- Dark matter search experiments
- Nuclear cross-section measurements

An Accelerator With Unique Capabilities

- Simultaneous delivery of multiple beam species (H^+ and H^-)
- Flexible beam structures for multiple user facilities
- Variable beam energies from the same Coupled Cavity Linac
- Intense short-pulse generation via Proton Storage Ring accumulation
- Advanced beam diagnostics and novel energy measurement techniques

A Facility Actively Evolving

- Multi-disciplinary workforce sustaining operations through 2050+

LANSCE Modernization Project (LAMP)

- Replacement of injector system and Drift Tube Linac
- Improved reliability and beam quality

LANSCE Enhancement Project (LANE)

- Expansion of experimental capabilities
- Alignment with future NNSA mission needs
- Enabling new physics and new materials studies

Questions?