

THE ATLAS MULTI-USER UPGRADE & NEW APPLICATIONS

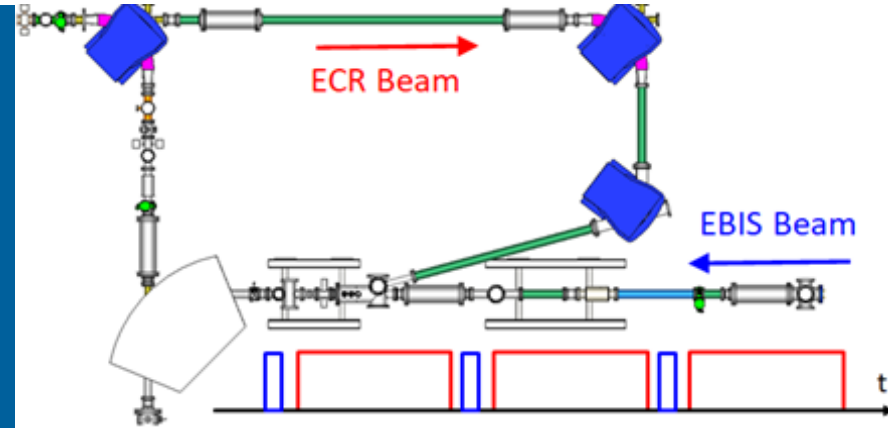

BRAHIM MUSTAPHA

Physics Division
Argonne National Laboratory

Outline

- ❑ Overview of ATLAS – R&D on Multi-Charge-State Ion Beam Acceleration
- ❑ The Need for and Purpose of the ATLAS Multi-User Upgrade
- ❑ The Opportunity and Potential Impact
- ❑ Concept, Scope, Requirements, Solution and Implementation
- ❑ Application: ATLAS Material Irradiation Station – (New beamline)
- ❑ Other Applications: Isotope R&D and Radiobiological Studies
- ❑ Summary

ATLAS: Argonne Tandem Linear Accelerator System

- ✓ 1st Superconducting heavy-ion linac in the world
- ✓ It has been operating for over 35 years
- ✓ National user facility serving ~ 400 users per year
- ✓ 1st Multiple charge state acceleration was demonstrated for a ^{238}U beam at ATLAS in 2000

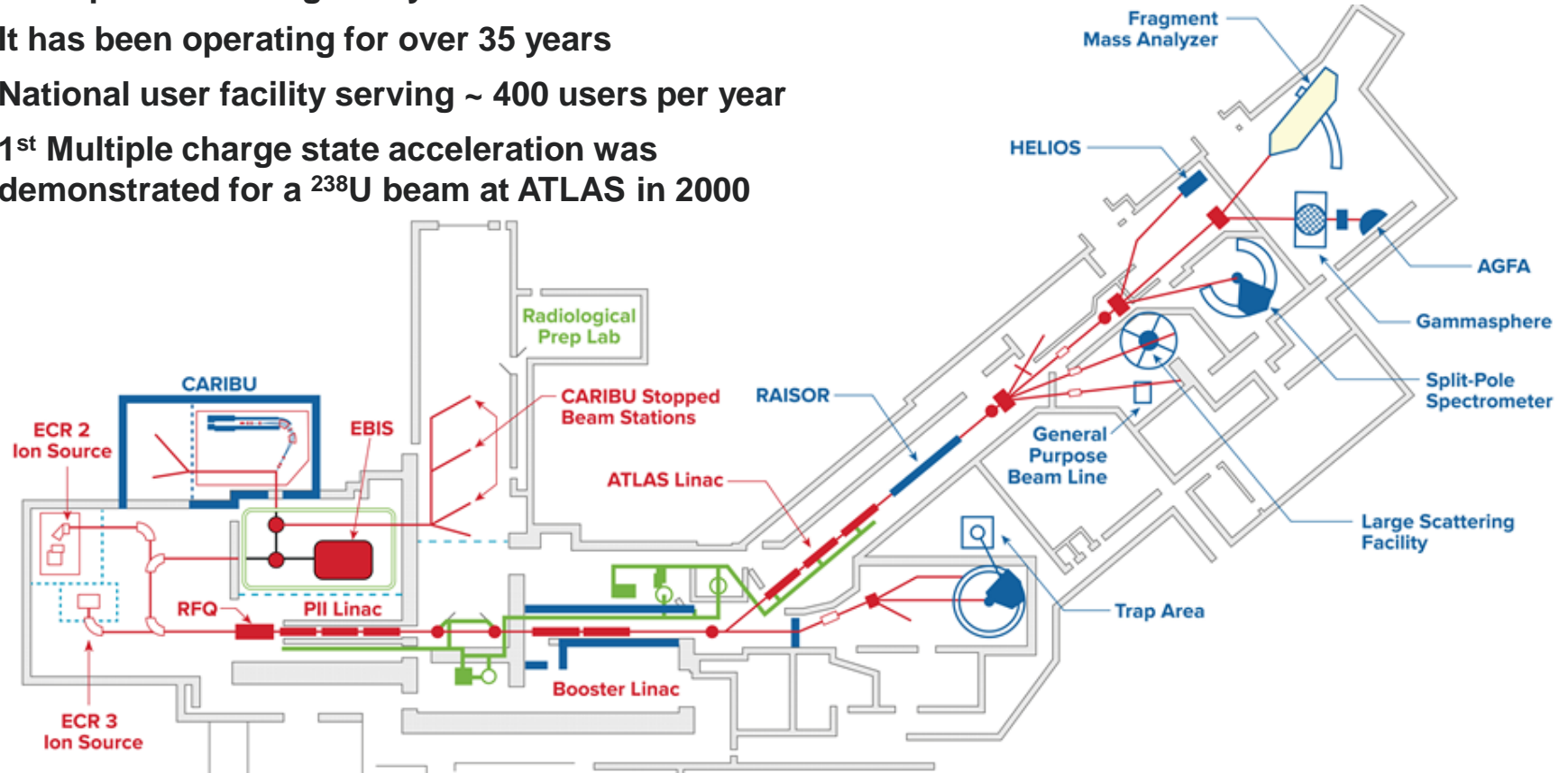

Simultaneous Multi-Charge State Acceleration

Simultaneous acceleration of multiply charged U-238 ions through a superconducting linac (ATLAS), P. Ostroumov et al, PRL 2001

^{238}U from PII, stripped and injected to Booster

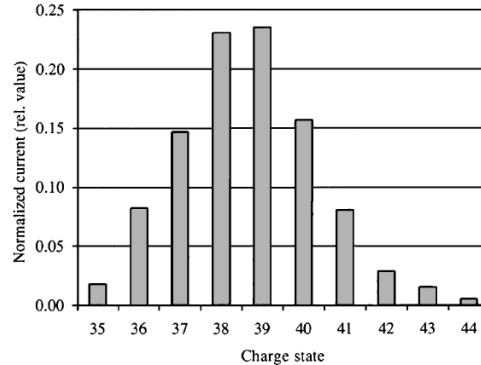
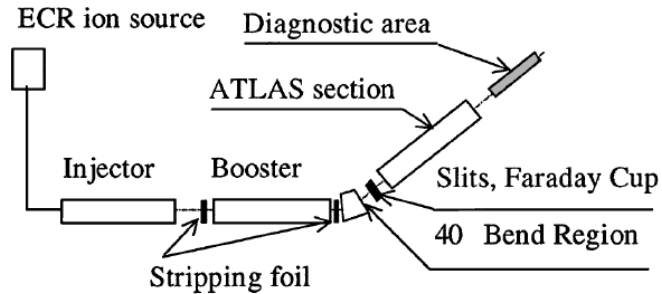

^{238}U Intensity distribution of accelerated Q's

Emittances & Twiss parameters for # Q's

| Uranium charge state | α_Y | β_Y mm/mrad | $\epsilon_{Y, \text{normalized}} \pi \times \text{mm} \times \text{mrad}$ |
|----------------------|------------|-------------------|---|
| 36+ | 0.72 | 12.66 | 0.94 |
| 37+ | 0.48 | 8.08 | 1.24 |
| 38+ | 0.06 | 10.17 | 1.11 |
| 39+ | 0.45 | 7.60 | 1.34 |
| 40+ | 0.54 | 9.22 | 1.03 |
| 41+ | -0.18 | 9.20 | 0.89 |
| 51+ | 0.60 | 9.00 | 2.69 |

Multi-Charge State Beam Transport & Injection

Combination and transport of a two charge states DC beam for RFQ injection

2Q-LEBT results, P. Ostroumov et al, PRST-AB, 2009

Test beamline, Bi beam from ECR

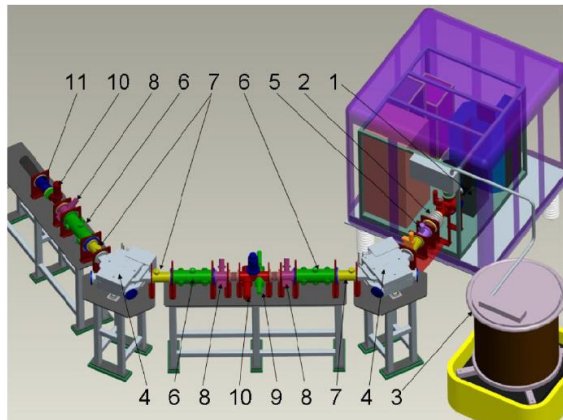

Sim. vs. Exp. Results

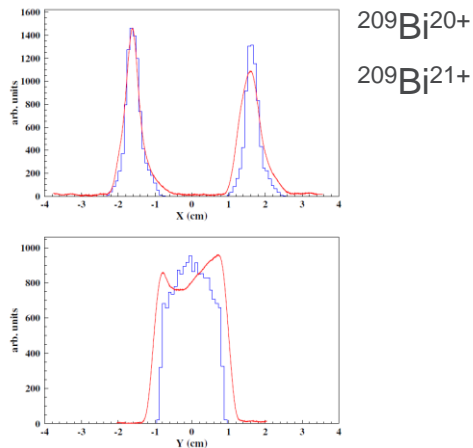

Experimental Results for # Q's

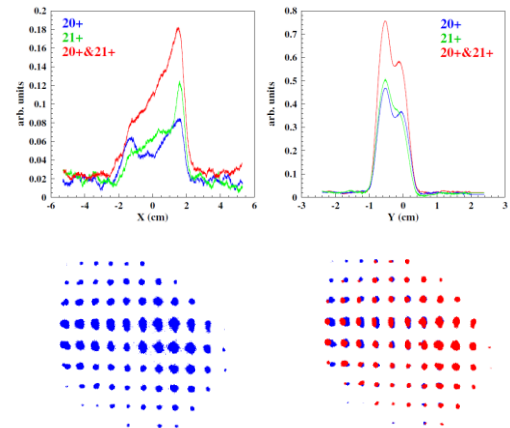

The Need & Purpose of the ATLAS MUU

❑ The Need

- Significant competition & increased pressure on ATLAS beam time
- Increasing demand for longer experiments (> 1 week)
- Examples: Low intensity RIBs & Low cross section reaction channels
- Requested beam time significantly exceeds ATLAS's ~ 6000 hours/year
- ATLAS PAC is typically over-subscribed by a factor of 2-3 ...

❑ The Purpose

- Relieving the pressure on beam time and accomplish more physics by serving two users at a time, allow more time for some applications
- When running CARIBU Beams, the machine is “empty” ~ 90% of the time while operating CW → Take advantage of that time (Economic!)
- Demonstrate multi-user capabilities that can be a model for similar facilities ...

The Opportunity with Pulsed CARIBU-EBIS

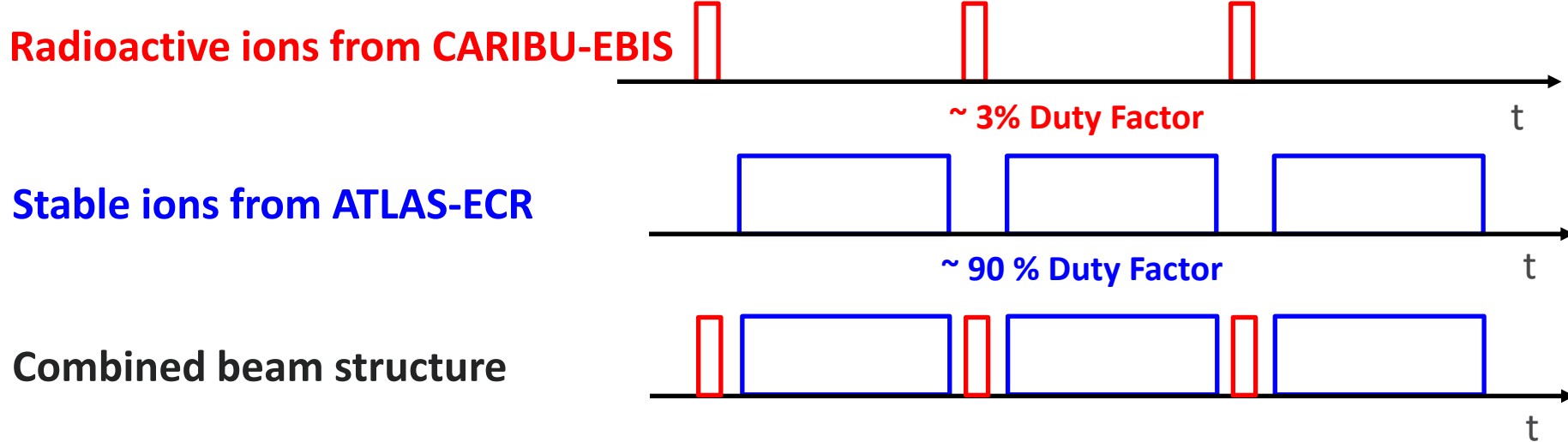

- ✓ EBIS beam is typically ~1 ms pulse up to 30 Hz repetition rate \rightarrow ~ 3 % DF
- ✓ DC beam from ECR could be injected into ATLAS in the remaining ~ 97% DF
- ✓ Considering 2 x 1 ms switching time, the useful ECR duty cycle can be ~ 90%
- ✓ CARIBU beams are typically charge-bred to corresponding $A/q \geq 4$, ATLAS accelerates beams with A/q ratios $\leq 7 \rightarrow$ The useful range of A/q overlap is 4-7

Combining ECR Stable beams with CARIBU RIBs

✓ Table shows beams within 1% of A/q ratio

✓ Overlap between stable and RIB beams offers a lot of flexibility

✓ Study of a recent run period showed ~40% potential overlap, limited only by the number of days of CARIBU beams

| A/Q | Stable beams | CARIBU beams |
|-------|---|---|
| 4.000 | $^{20}\text{Ne}^{5+}$, $^{28}\text{Si}^{7+}$, $^{36}\text{Ar}^{9+}$ | $^{84}\text{Se}^{21+}$, $^{88}\text{Kr}^{22+}$, $^{92}\text{Sr}^{23+}$, $^{101}\text{Mo}^{25+}$, $^{105}\text{Ru}^{26+}$ |
| 4.143 | $^{58}\text{Ni}^{14+}$ | $^{83}\text{As}^{20+}$, $^{95}\text{Y}^{23+}$, $^{104}\text{Tc}^{25+}$, $^{112}\text{Pd}^{27+}$, $^{117}\text{Cd}^{28+}$ |
| 4.364 | $^{48}\text{Ti}^{11+}$, $^{74}\text{Ge}^{17+}$ | $^{92}\text{Kr}^{21+}$, $^{105}\text{Nb}^{24+}$, $^{109}\text{Tc}^{25+}$, $^{119}\text{Pd}^{27+}$, $^{149}\text{Nd}^{34+}$ |
| 4.538 | $^{59}\text{Co}^{13+}$ | $^{91}\text{Rb}^{20+}$, $^{105}\text{Zr}^{23+}$, $^{123}\text{Cd}^{27+}$, $^{131}\text{Te}^{29+}$, $^{146}\text{Pr}^{32+}$ |
| 4.875 | $^{78}\text{Kr}^{16+}$ | $^{93}\text{Y}^{19+}$, $^{102}\text{Mo}^{21+}$, $^{132}\text{Sn}^{27+}$, $^{141}\text{I}^{29+}$, $^{162}\text{Eu}^{34+}$ |
| 5.000 | $^{40}\text{Ar}^{8+}$, $^{60}\text{Ni}^{12+}$, $^{90}\text{Zr}^{18+}$ | $^{85}\text{Se}^{17+}$, $^{110}\text{Mo}^{22+}$, $^{124}\text{In}^{25+}$, $^{141}\text{I}^{28+}$, $^{159}\text{Pm}^{32+}$ |
| 5.280 | $^{132}\text{Xe}^{25+}$ | $^{105}\text{Ru}^{20+}$, $^{126}\text{In}^{24+}$, $^{137}\text{I}^{26+}$, $^{153}\text{Pr}^{29+}$, $^{165}\text{Tb}^{31+}$ |
| 5.600 | $^{84}\text{Kr}^{15+}$ | $^{100}\text{Nb}^{18+}$, $^{111}\text{Tc}^{20+}$, $^{117}\text{Cd}^{21+}$, $^{141}\text{Xe}^{25+}$, $^{147}\text{La}^{26+}$ |
| 5.643 | $^{79}\text{Br}^{14+}$, $^{107}\text{Ag}^{19+}$ | $^{96}\text{Rb}^{17+}$, $^{107}\text{Nb}^{19+}$, $^{119}\text{Cd}^{21+}$, $^{135}\text{Te}^{24+}$, $^{151}\text{Nd}^{27+}$ |
| 5.714 | $^{80}\text{Se}^{14+}$ | $^{91}\text{Kr}^{16+}$, $^{97}\text{Zr}^{17+}$, $^{109}\text{Ru}^{19+}$, $^{131}\text{Sb}^{23+}$, $^{143}\text{Ba}^{25+}$ |
| 6.432 | $^{238}\text{U}^{37+}$ | $^{83}\text{Se}^{13+}$, $^{90}\text{Kr}^{14+}$, $^{97}\text{Sr}^{15+}$, $^{103}\text{Zr}^{16+}$, $^{141}\text{I}^{22+}$ |
| 6.709 | $^{208}\text{Pb}^{31+}$ | $^{88}\text{Se}^{13+}$, $^{88}\text{Br}^{13+}$, $^{94}\text{Rb}^{14+}$, $^{100}\text{Y}^{15+}$, $^{107}\text{Nb}^{16+}$ |
| 6.792 | $^{197}\text{Au}^{29+}$ | $^{89}\text{Se}^{13+}$, $^{89}\text{Br}^{13+}$, $^{95}\text{Rb}^{14+}$, $^{102}\text{Y}^{15+}$, $^{108}\text{Nb}^{16+}$ |
| 7.000 | $^{133}\text{Cs}^{19+}$ | $^{84}\text{As}^{12+}$, $^{98}\text{Rb}^{14+}$, ... |

Potential Impact / Gain based on PAC-Approved Experiments with CARIBU beams available

- ❑ We analyzed PAC-approved experiments that ran during one of GRETINA campaigns for potential overlap between stable beams and CARIBU beams





- ❑ Analysis procedure and criteria for beam overlap
 - Source: One beam from ECR-2 & One beam from CARIBU
 - Mass-to-charge ratio: Both beams with $A/q > 3.5$
 - Energy: One beam at Booster & One beam at ATLAS energy (only Booster energy beams can run in Area-II)
 - Experimental equipment: Area-II has limited operational equipment
→ Added hypothetical case: GRETINA located in Area-II

- Findings
 - ✓ With a gamma ray detector (GT/GS) located in Area-II, the potential overlap is ~ 40%, limited only by the approved days of CARIBU beams

Nuclear Physics Programs to Benefit from the ATLAS MUU

- ✓ Heavy element program ($Z > 100$) (AGFA separator + Digital GS)
 - ✓ Decay spectroscopy & super-heavy program (AGFA + DSSD)
 - ✓ Astrophysics capture reaction program (AIRIS + MUSIC)
 - ✓ High resolution spectroscopy of nuclei (CARIBU and AT-TPC)
 - ✓ Coulomb excitation studies (CARIBU + GRETINA & CHICO-II)
 - ✓ Single particle structure studies (CARIBU + HELIOS)
 - ✓ High resolution single particle structure (AIRIS + HELIOS)
- **Most / All of these programs require long experimental runs, limited at this time but would run with the ATLAS-MUU**
- **More beam time from the ATLAS-MUU will help these programs reach their full potential.**

Concept & Scope of the ATLAS MUU

-  Injection from ECR
-  Injection from CARIBU-EBIS
-  4 - 7 MeV/u beam to Area II
-  4 -15 MeV/u beam to Area III or IV

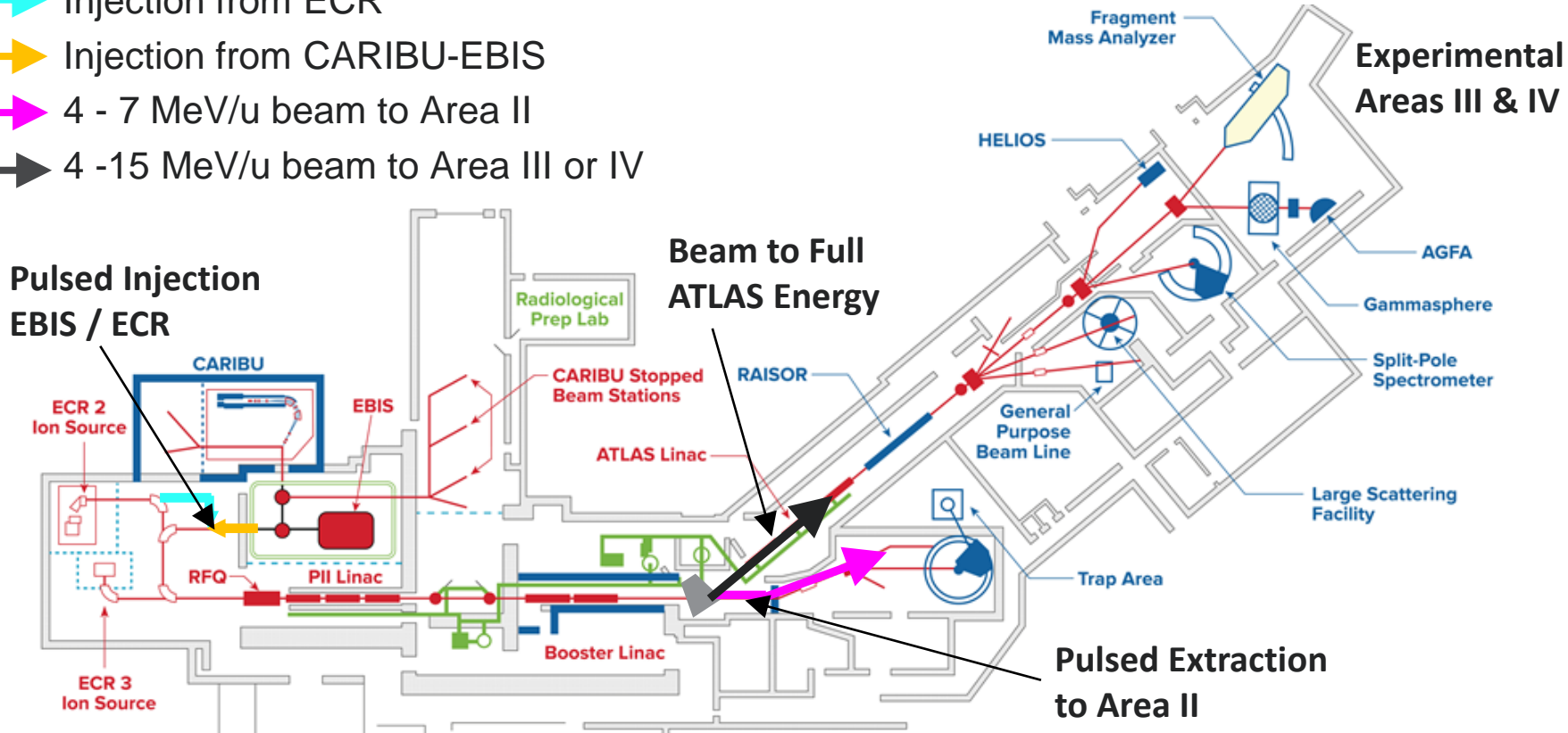

Requirements: Two Beam Injection & Extraction

➤ Pulsed injection in the LEBT

- ✓ Properly combine two beams with ~ 1 ms switching time
- ✓ Maximize the overlap of the two beams in phase space
- ✓ Match velocities of both beams for injection to the RFQ
- ✓ Have proper beam diagnostics, especially for weak beams

➤ Pulsed extraction after the Booster

- ✓ Switch either beam to Area II, the other to ATLAS and Area III&IV
- ✓ Fit into the available space, this is a major constraint
- ✓ Maintain single beam operation: Keep existing elements & diagnostics
- ✓ Compatible with potential future upgrades

Technical Solution

1) Modification to the Front-end / Injection

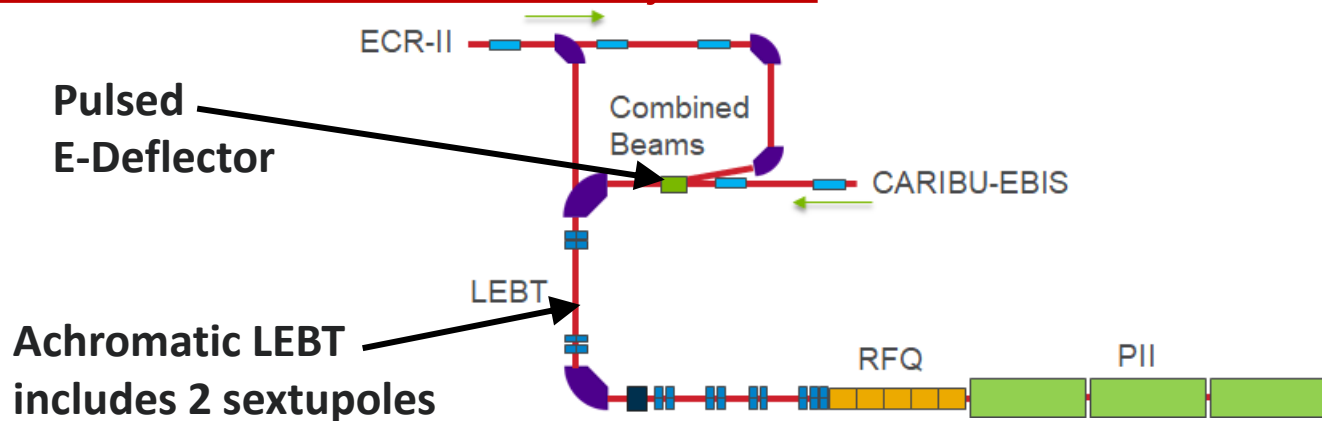

2) Extraction added after the Booster section

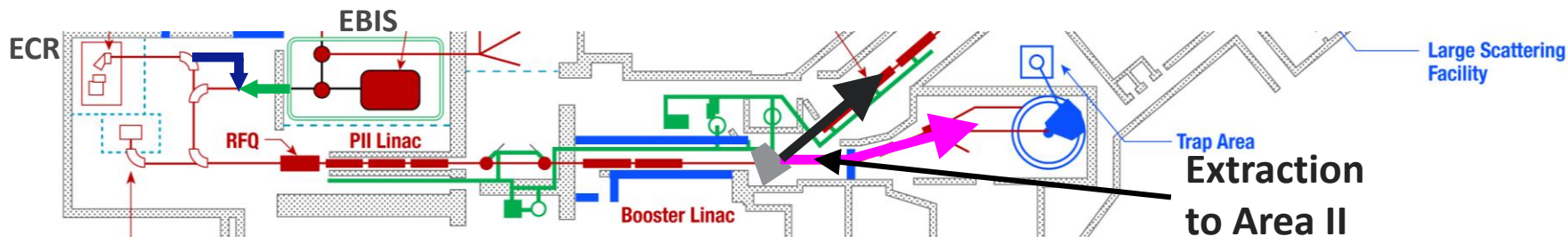

LEBT Injection: Combining Two Beams

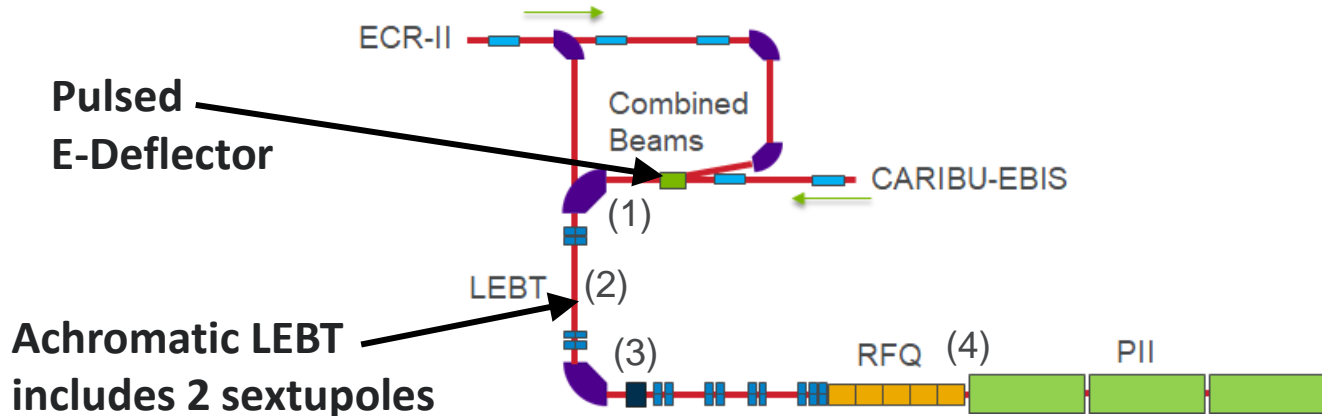

Example: $^{132}\text{Sn}^{27+}$ from CARIBU-EBIS

$^{48}\text{Ca}^{10+}$ from ECR2

with $\sim 2\%$ in A/q

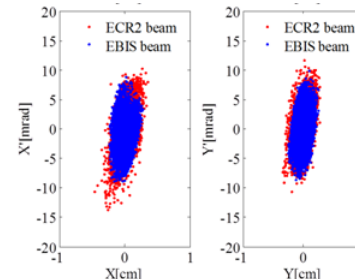
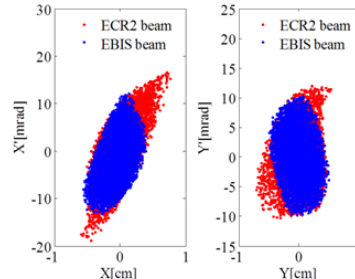
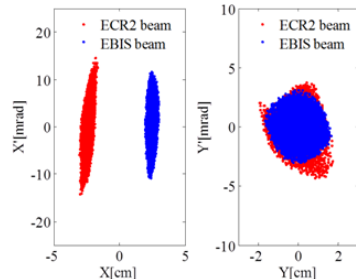
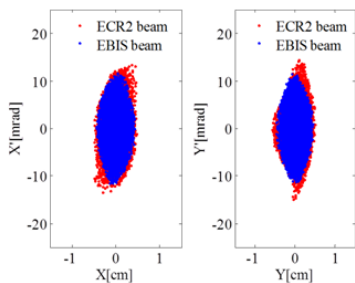

(1) Before 180° bend (2) At selection slit

(3) After 180° bend

(4) After ATLAS RFQ

Booster Switchyard: Extracting One Beam

- ✓ ATLAS line unchanged – Pulsed chicane to Area II
 - Keeps the existing bending configuration to ATLAS
 - Space between kicker and buncher for Diagnostics
 - Compatible with future Booster upgrade

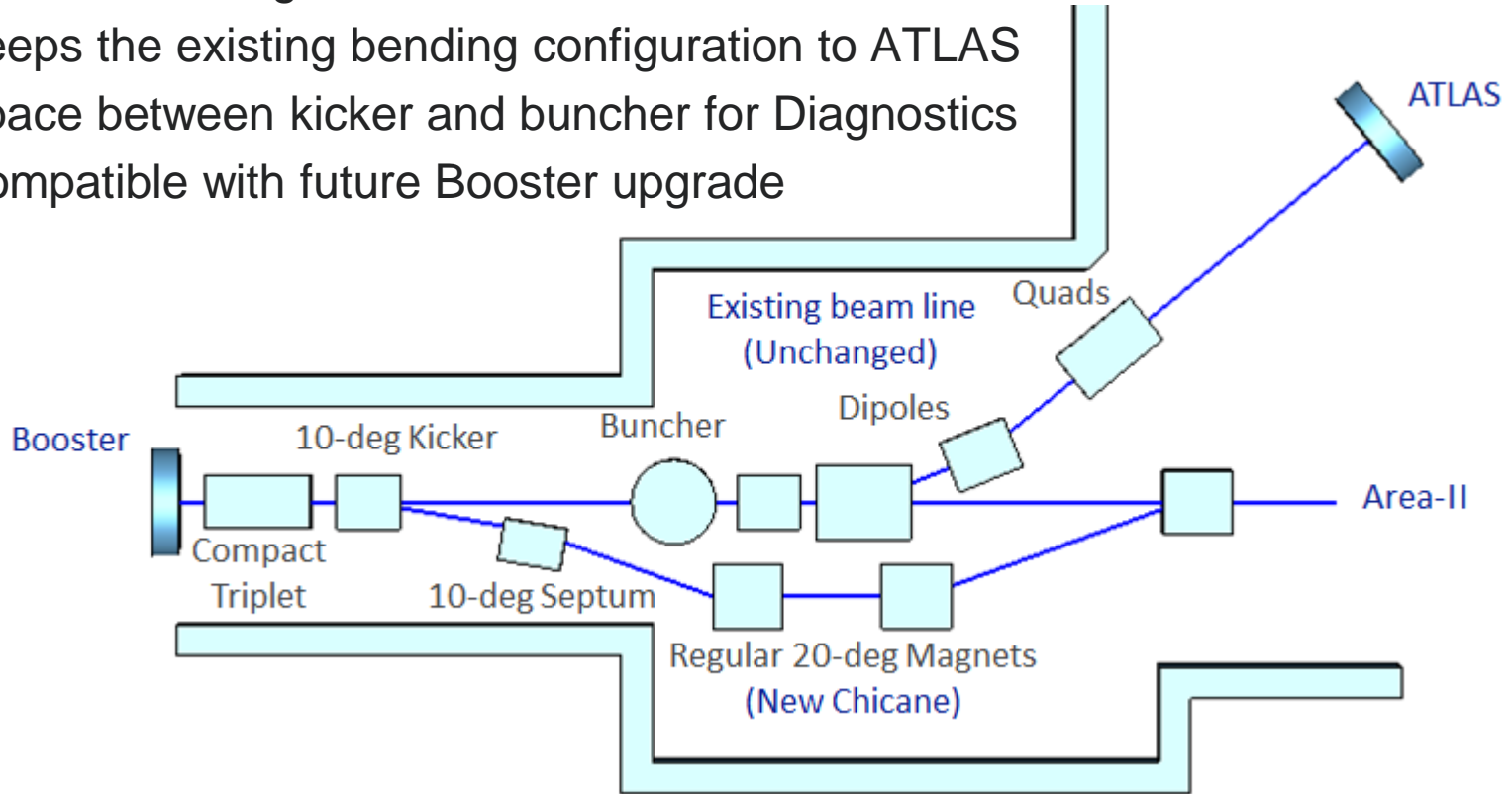

Booster Switchyard: Beam Optics

Beam to **ATLAS** through original beam line, a compact triplet is inserted right after Booster

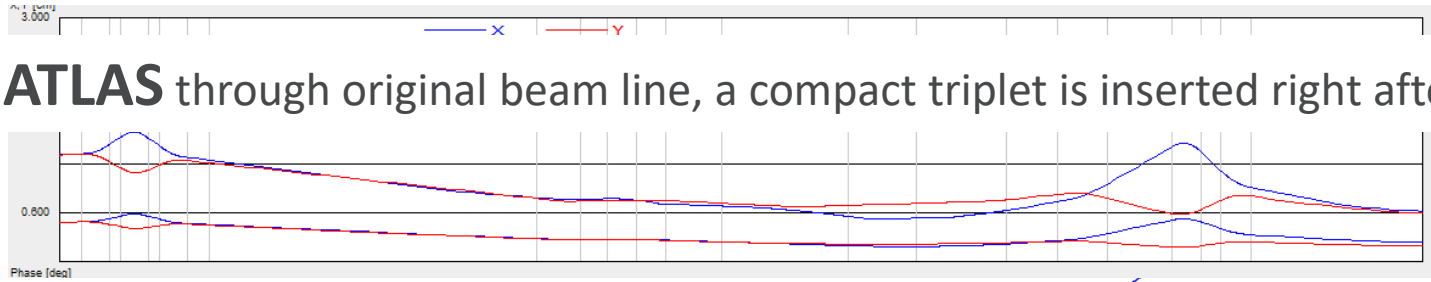

Booster

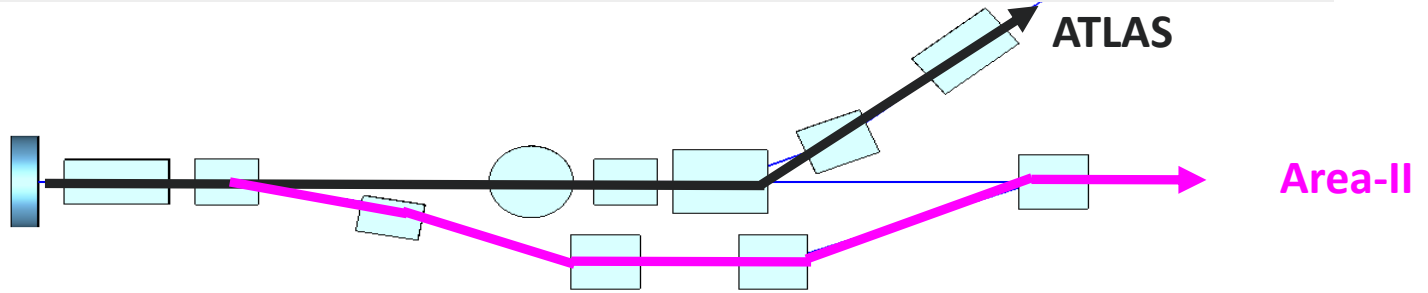

Beam to **Area II** through a new chicane made of a kicker, a septum and 3 regular magnets

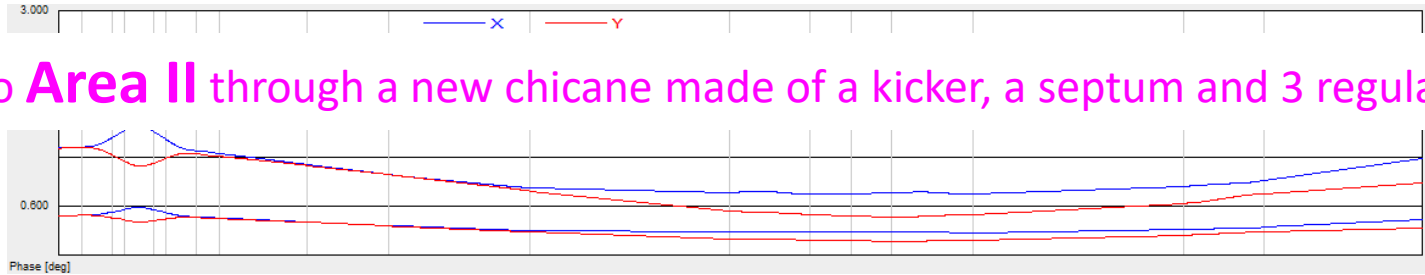

Main Components for the ATLAS MUU

LEBT Injection

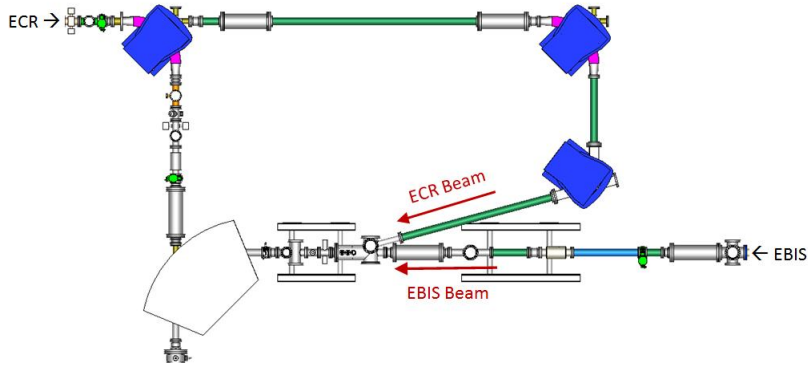

- Pulsed electrostatic deflector
- 2 electrostatic sextupoles

Booster Switchyard

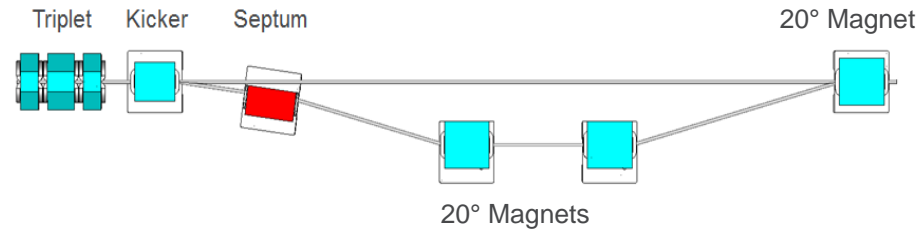

- Compact triplet
- Pulsed kicker-magnet - 10°
- Septum-magnet - 10°

Kicker Magnet – Most Critical Component

■ Design Requirements

- ✓ Should be able to kick a 5 MeV/u $A/q=6$ beam by $10^\circ \rightarrow \sim 0.7$ T (0.5 m)
- ✓ Rise and fall time of ~ 1 ms with 30 Hz rep-rate
- ✓ Two operation modes: 1) 3% ON, 97% OFF and vice versa $\rightarrow \sim$ DC

■ Main Consequences

- ✓ For $B \sim 0.7$ Tesla, It can't be a Ferrite, It has to be Iron/Steel
- ✓ Very thin laminations required to reduce AC losses from eddy currents
- ✓ Power supply should operate in pulsed and \sim DC modes

■ Magnets with Similar Parameters: Very Few ...

- ✓ LANL–IPF kicker (0.98 T, 60 Hz, 5 ms rise/fall, excessive losses!)
- ✓ RAL–ISIS kicker (0.86 T, 10 Hz, 12 ms rise/fall, successful!)

Results from a Recent Experimental Test Run

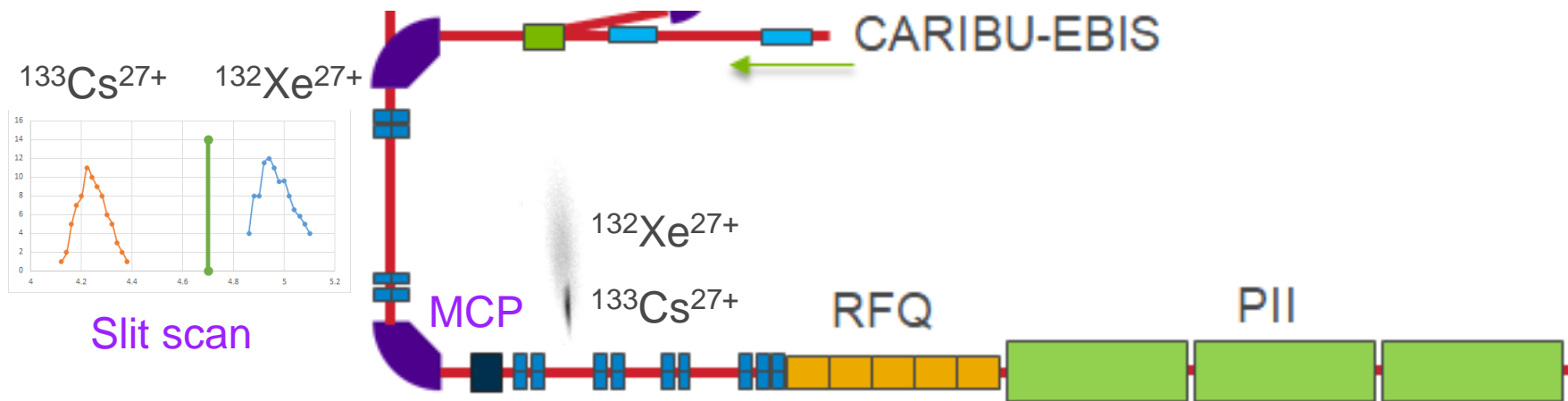

✓ Since the ECR/EBIS combiner line is not available (part of project), the test was done using two EBIS beams: $^{133}\text{Cs}^{27+}$ and $^{132}\text{Xe}^{27+}$

✓ Two beams successfully combined, injected and accelerated through RFQ, PII and Booster sections with ~ 70% total transmission

APPLICATIONS



Argonne National Laboratory is a
U.S. Department of Energy laboratory
managed by UChicago Argonne, LLC.

Material Irradiation Studies for Nuclear Energy

Radiation damage mechanisms

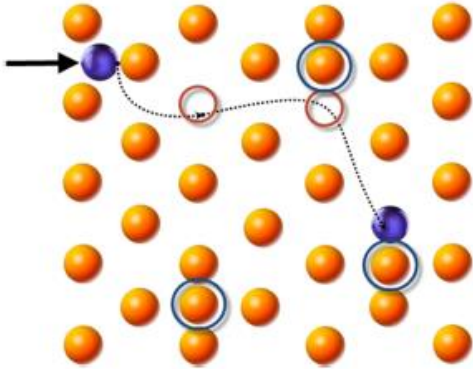

Damage as function of depth

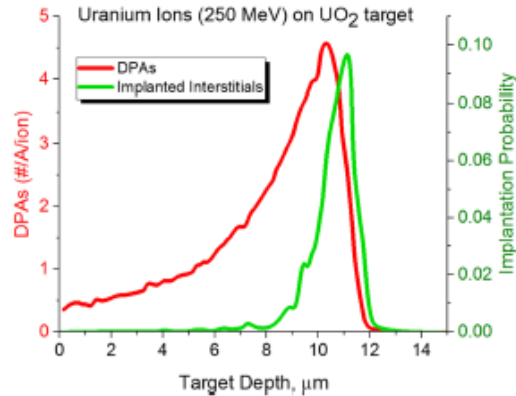

Current Irradiation Station at ATLAS

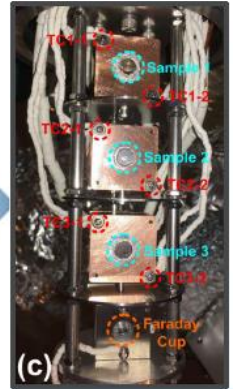

- Low-energy heavy ion beams ~ 1 MeV/u can effectively emulate material damage in nuclear reactors, in both fuel and structural materials
- Damages that could take years in a reactor environment could in principle be reproduced in few days or hours using an ion accelerator
- Following irradiation, materials are analyzed and their robustness and adequacy for nuclear reactor environment is evaluated
- Ref: M. Pellin et al, Journal of Nuclear Materials 472 (2016) 266-271.

AMIS: ATLAS Material Irradiation Station (New)

A dedicated material irradiation station after PII

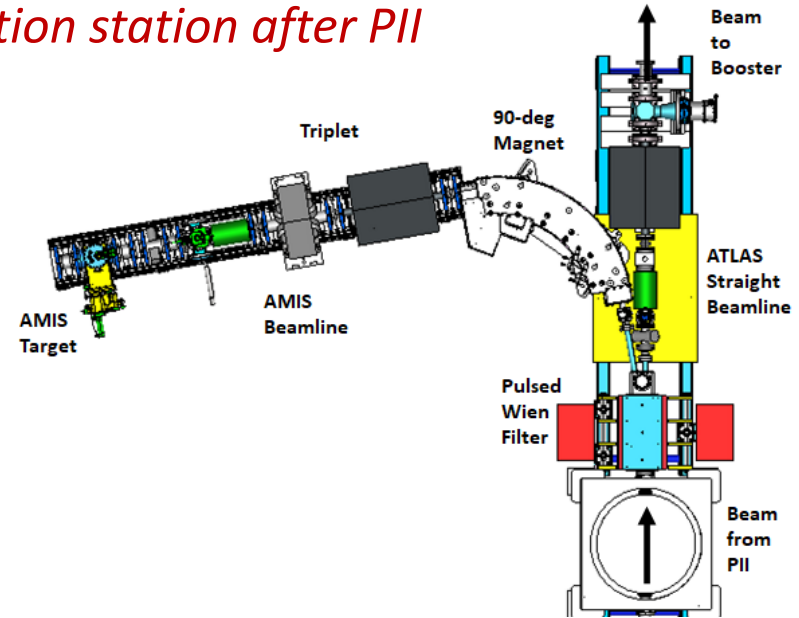
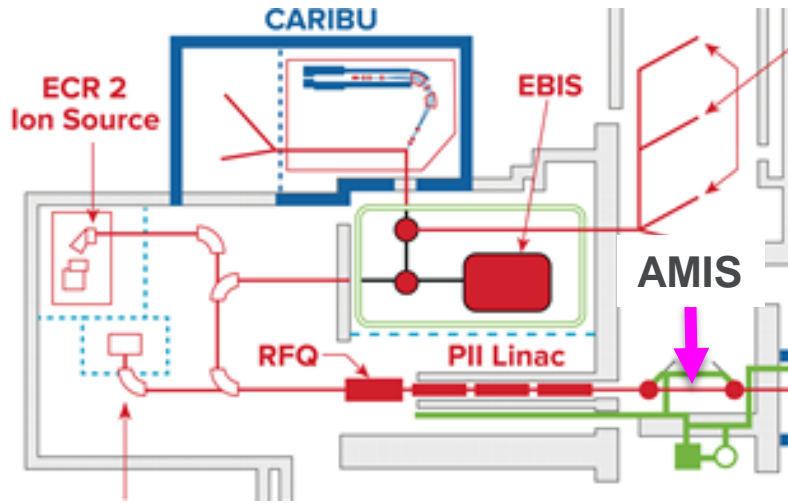

- Pulsed switching using a pulsed Wien filter magnet will allow more beam time by taking advantage of the ATLAS multi-user upgrade
- The new beamline is currently under development, will be completed by end of fiscal year
- Funding: NNSA's Office of Defense Nuclear Nonproliferation

AMIS Beamline: Key Components

10-deg Pulsed Wien filter magnet

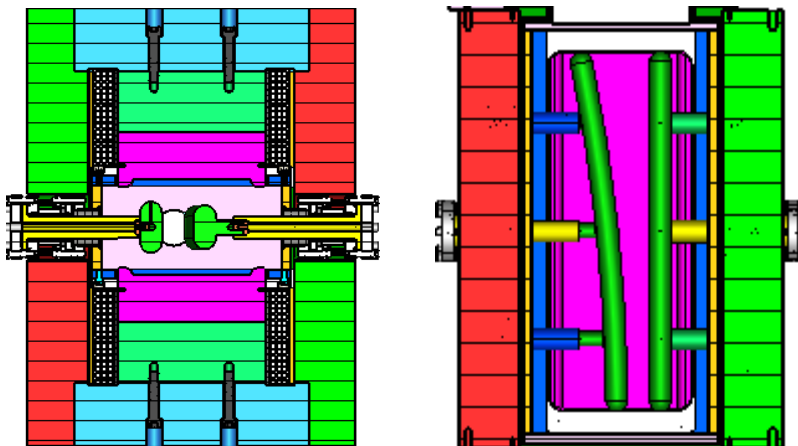

- Combines E&B fields
- Pulsed E-field, DC B-field
- E&B add-up to deflect beam to AMIS target
- E changes sign to cancel B-field for straight beam



90-deg Septum magnet



- Thick Septum ~ 5 cm for beam separation
- Magnetic shielding to limit effect on straight ATLAS beam

Medical Isotope Production R&D at ATLAS

Production of Alpha-emitting ^{211}At using ^6Li

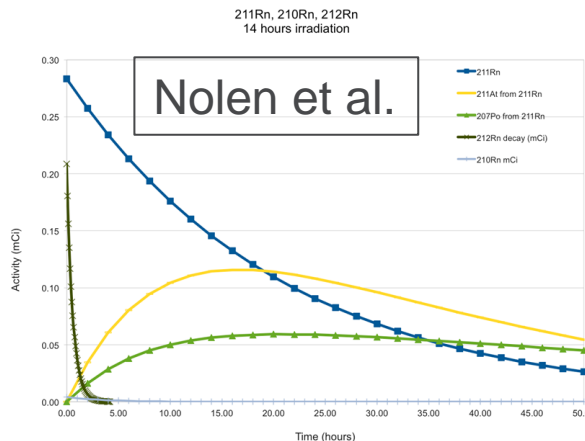

Auger-emitting Isotopes

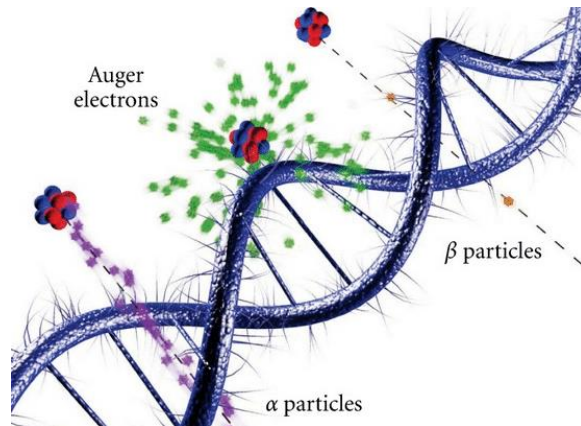

Production through ^{209}Bi (^7Li , $5n$) ^{211}Rn \rightarrow ^{211}At

- Light ion beams such as $^3,4\text{He}$ and $^6,7\text{Li}$ are useful for the production of alpha-emitting and Auger-electron-emitting isotopes
- Many potentially useful isotopes are accessible at ATLAS using such light ion beams.
- The production cross sections are ~ 1 barn enabling significant yields of isotopes and the useful ion energy range is $\sim 8\text{-}15$ MeV/u which has excellent overlap with ATLAS capability.

Many possible candidates ...

New Beamline for Isotope R&D at ATLAS

A dedicated beamline and target enclosure

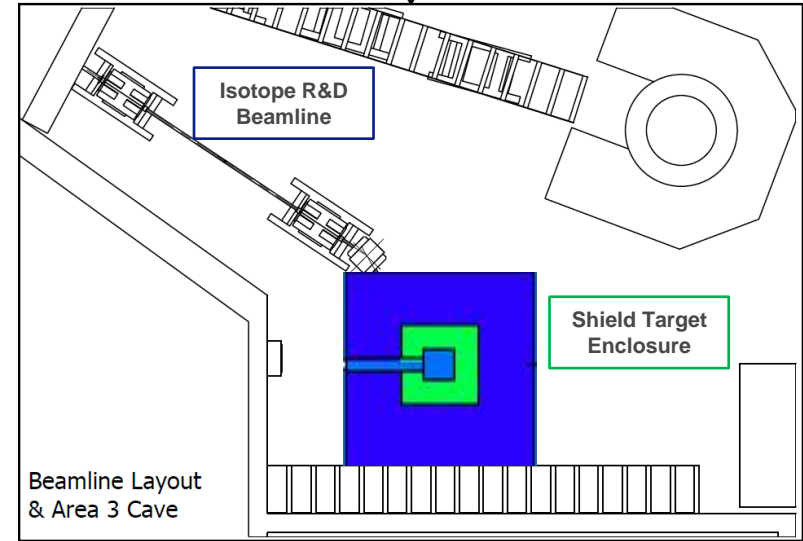
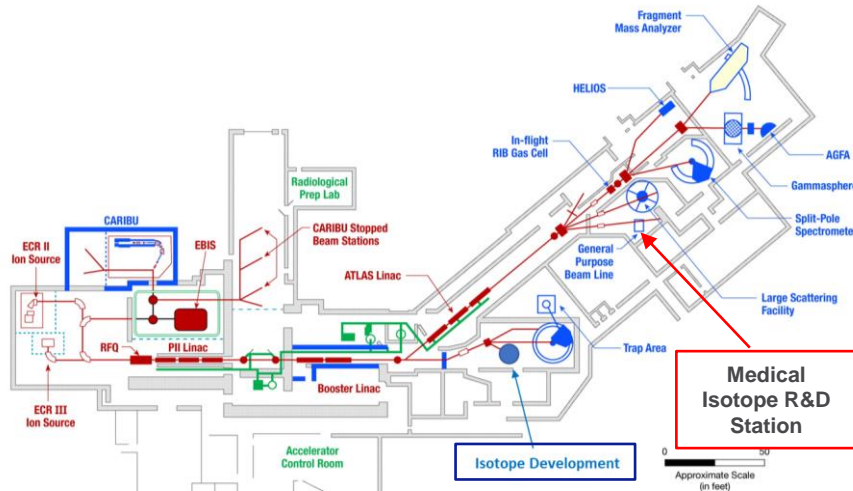

- To maximize overlap with RIB beams in the multi-user mode, the light ions (He, Li) can be accelerated in 1+ charge state up to the Booster, then stripped and accelerated in ATLAS
- In addition to Areas 3 and 4, some Isotope Development can be done in Area 2

Ion Beam Therapy: Thermoacoustic Imaging

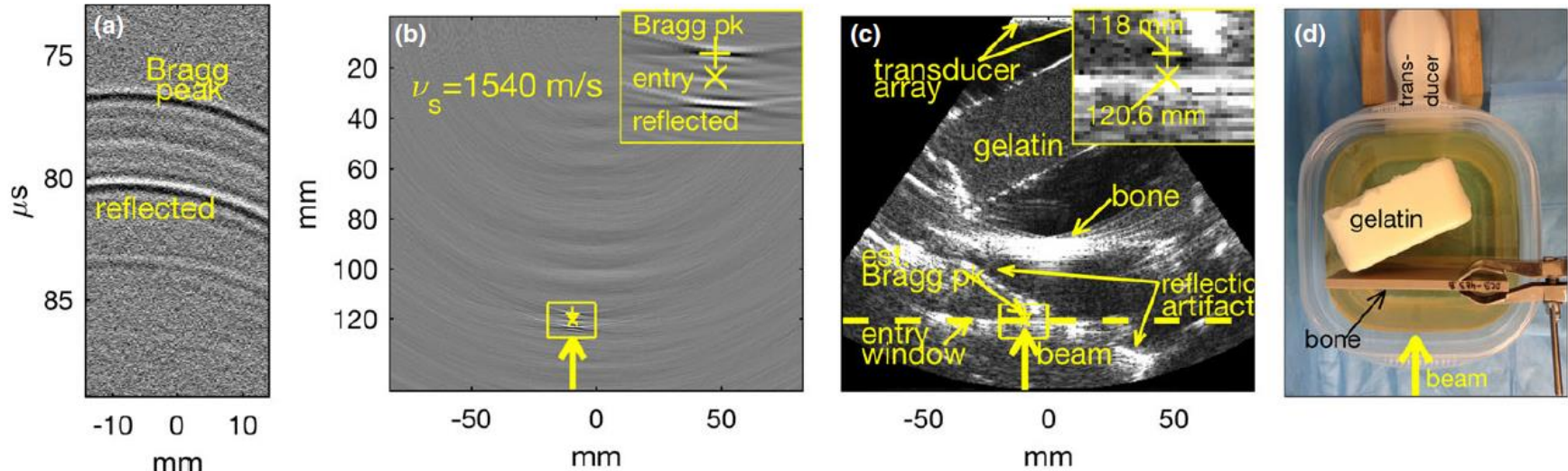

S. Patch et al, Med. Phys. 46 (1), January 2019

- Before stopping in media, ions lose a significant part of their energy (Bragg peak), a pressure wave is generated and can be detected if the ion beam is pulsed at a certain rate
- This enables the measurement of the ion beam range to the mm level
- Recent experiments performed at ATLAS with protons, helium, and carbon ions studied the robustness of thermoacoustic range verification to acoustic inhomogeneity in different media

Cellular Radiobiology Studies at ATLAS

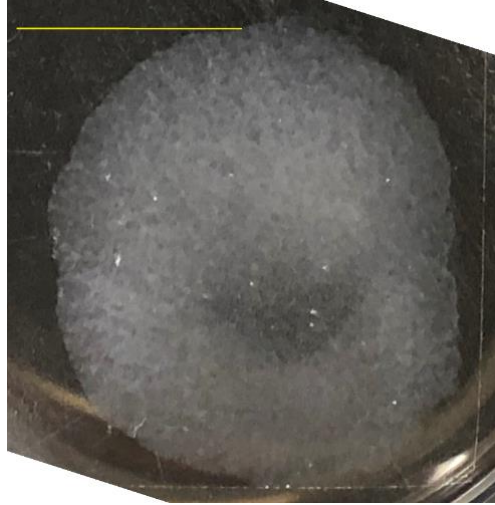

Outline of a circular cluster of cancer cells (UM-SCC-104) 5 days after exposure to Li ion beam (yellow bar – 10mm). Cell killing caused by radiation exposure caused darkening in the cell cluster (loss of biomass). The clear dark spot shows the precision of cell killing by Li beam: shape of cell loss matches the shape of the ion beam.

T. Paunesku et al, Feinberg School of Medicine, Northwestern University

- Using ATLAS's low-energy light ions from protons to neon, many fundamental issues related to the radiation cellular biology of ion beam therapy can be investigated
- Examples: the response of a variety of human cells to various doses of light ions covering a wide range of dE/dx (LET), and detailed studies of their relative biological effectiveness (RBE)
- Recent experiments with the goal of exploring the response of several types of human cells to the Bragg peak of protons, lithium beams, and carbon beams took place at ATLAS

Summary

- ❑ The ATLAS Multi-User Upgrade will relieve the pressure on beam time at ATLAS and enhance the capabilities of the facility
- ❑ The additional beam time expected from this upgrade will boost the delivery of the nuclear physics program and open-up the opportunity for some applications
- ❑ The design concept and technical solution were developed to satisfy the requirements of the multi-user upgrade with minimal interference with single beam operations
- ❑ We recently demonstrated the combination and acceleration of two beams with good efficiency all the way through Booster, the beam switching point.
- ❑ The project was recently reviewed and approved by the DOE/NP

THANK YOU



Argonne National Laboratory is a
U.S. Department of Energy laboratory
managed by UChicago Argonne, LLC.

